

VONDOM[®]
DESIGNERS

DESIGNER

WTF?

FABIO NOVEMBRE / F3 / AND
ROSS LOVEGROVE / BIOPHILIA
ORA-ÏTO / UFO
EERO AARNIO / ROULETTE / PEACOCK / ROSINANTE
ARCHIRIVOLTO / PEZZETTINA / FIESTA
RAMÓN ESTEVE / FRAME / FAZ / VELA
KARIM RASHID / SPAGHETTI / KANNELLONI / VERTEX / DOUX /
SURF / PAL / LAVA / VLEK
STEFANO GIOVANNONI / BLOW / STONES / PILLOW
A-CERO / WING / ALMA / REST
MARISCAL / MOMA / SABINAS / MORA / BLANCA
JMFERRERO_ESTUDI{H}AC / VASES / MARQUIS
TERESA SAPEY / ADAN / CHEMISTUBES / CHRISMY
LUDOVICA + ROBERTO PALOMBA / BONES
HARRY & CAMILLA / BYE-BYE
AGATHA RUIZ DE LA PRADA / AGATHA
GABRIELLE + OSCAR BURATTI / KES
EUGENI QUILLET / BUM BUM
JORGE PENSI DESIGN STUDIO / FLAT



RAMÓN ESTEVE / ART DIRECTOR

EDITORIAL

VONDOM ART DIRECTOR, RAMÓN ESTEVE TELLS US ALL FEATURES, HIGHLIGHTS AND EVENTS THAT HAVE TAKEN PLACE THIS SEASON 2013-14, ALL CHALLENGES THAT HAS STARRED VONDOM, FESTIVALS, NEWS AND RECOGNITION ACHIEVED THROUGH TEAMWORK AND THE MORE INTERNATIONAL INNOVATION AND DESIGN COMMITMENT.

The time is 8 pm and I'm waiting in the International Airport of Mexico City to catch my flight to JFK (NYC). There, in the world's most influential city for art and culture, will start a new phase, which begins with the creation of the VONDOM showroom.

While I look on my Ipad at my most recent purchase, a book by Eames, without a doubt a couple who are among the most influential furniture designers of recent decades, I receive a call from José Albiñana requesting that I write the prologue for the Designer's Catalogue. Well, to be honest, he didn't actually use the word "prologue", but said: "I would like you to describe what VONDOM has meant to you this last year". Stunned at his question I stop, think for a few moments, and then accept without a doubt. As the firm's artistic director, and a designer, it is a challenge for me to look back and recall everything that has happened. Actually, until I have a clean sheet from my notebook and a pen in front of me, I'm unaware of how far we have managed to come.

Let's begin. I could sum up this past year in two sentences: "Design has no limited boundaries or rules. It has a passport, full of stamps, which are evidence of the recognition of this brand, VONDOM". Excuse me reader. I can't end there. The starting point of this peculiar journey is curious, to say the least. It is already over 5 years ago that VONDOM decided to de-

vote itself to increasing the value of its materials by means of design. It began to do so with the help of well-known figures from a national scope, such as Mariscal and A-Cero, as well as an International scope, such as Karim Rashid and Stefano Giovannoni. In line with the fashion fads of that year it also decided to include leading figures in its "Big List" including Eugeni Quitllet, Jorge Pensi, Gabriele+Oscar Buratti. This was when the first part of its new endeavors were revealed, which would be characterized by new colours and materials, for example taupe and khaki. As the months went by the new collections by Ora Ito, Ross Lovegrove and Fabio Novembre were noticed by Paris, Cologne, Shanghai, Birmingham, Dubai, Moscow and other places. But this firm's intentions right from the start haven't only been to present its newest and latest items. Instead its aim is to convey to people a way of life, an essence, or rather "Its essence". VONDOM, is a synonym for Versatility, Originality, Novelty, Distinction, Fashion. In other words, a way of life.

VONDOM has reached out even further, stepping up its activity and creating a stir. Its launch in the International Furniture Fair of Milan was evidence of this. I still remember what Soledad Lorenzo, Director of the Architecture and Design magazine said minutes before VONDOM's Alle Terme Spa Event began in Milan: "This night will be a unique experience". As I heard Sole say that word, "unique", I realized then that that day would mean a new beginning.

01



Over a 1,000 people lived VONDOM's essence that night, in a unique place, without equal, QC Termemilano. I think I speak on behalf of all there when I say that those who attended remember the surrounding atmosphere that we created, which flowed with design, art, relaxation and well-being.

The months continued passing by and a well-deserved moment arrived when we were awarded Karim Rashid's prize, as winner of the Good Design Awards, with the Sloo chair. Also we received much recognition from national and international press. "VONDOM, an emblem at the vanguard" "VONDOM impacts on design", "VONDOM, the volumetric architecture", "VONDOM lights up the centre of Seoul with it's new showroom", are just some of the headlines which highlighted the power transmitted by our mainly outside furniture and lighting. As this year drew to a close something was needed to summarize and illustrate that time of new ties, events and projects we've had on a worldwide scale. For this reason the Vondom Atmospheres Catalogue was made, which gathered all this together in 184 pages. I still wonder how the the Graphic team has been able to include so many things on so few pages. Also I would like to invite you to explore www.vondom.com's News section. Yes, you also may wonder how we have been able to sum up so much news, as well as over 70 collections and about 600 products in just 500gr.

It has been a year in which VONDOM has furnished a great number of projects around the world, has invited thousands of VIPs to it's exclusive events and has sponsored a great many events in the worlds of fashion, sports, films, cars and design. Among the most exciting moments have been: The Design Circus in Australia, the XL/xs exposition "Designed by Architects", the Valencia Open 500 tournament, the 50th Anniversary of Spain's most published magazine, the Telva and Cannes International Film Festival, along with many other events VONDOM has been a part of.

It's a fact: It's impossible to stop creating and dreaming. As Anne Win-tour would say "Fashion isn't about looking behind. It is always about looking forward".

WE ARE VONDOM.

- 01) NEW CATALOG VONDOM PROJECTS.
- 02) VONDOM A LAS TORRES.
- 03) CANNES FILM FESTIVAL LOUNGE.

02



03



INTERVIEW WITH RAMON ESTEVE DURING AN EVENT.



OUR STAND AT THE FAIR OF MILAN.



THE CREATIVE TEAM FULL PERFORMANCE, RAMON ESTEVE STUDIO.

SR. FABIO NOVEMBRE

FABIO NOVEMBRE WAS BORN IN LECCE IN 1966. HE MOVED TO MILAN IN 1984, WHERE IN 1992 HE RECEIVED A DEGREE IN ARCHITECTURE. IN 1993 HE LIVED IN NEW YORK CITY WHERE HE ATTENDED A MOVIE-DIRECTION COURSE AT THE NEW YORK UNIVERSITY. IN 1994, HE WAS COMMISSIONED TO DESIGN HIS FIRST PROJECT: THE "ANNA MOLINARI BLUMARINE" SHOP IN LONDON. IN THE SAME YEAR HE OPENED HIS OWN STUDIO IN MILAN. FROM 2000 UNTIL 2003 HE WORKED AS ART DIRECTOR AT BISAZZA, CONTRIBUTING IN THE INTERNATIONAL GROWTH OF THE MOSAIC TILE BRAND. SINCE 2001 HE HAS WORKED FOR ITALIAN DESIGN BRANDS SUCH AS CAPPELLINI, DRIADE, MERITALIA, AND CASAMANIA AND ALSO INTERNATIONAL BRANDS AS VONDOM.

Who really are you?

—Since 1966, I've responded to those who call me Fabio Novembre. Since 1992, I've responded to those who also call me "architect". I cut out spaces in the vacuum by blowing air bubbles, and I make gifts of sharpened pins so as to insure I never put on airs. My lungs are imbued with the scent of places that I've breathed, and when I hyperventilate it's only so I can remain in apnea for awhile. As though I were pollen, I let myself go with the wind, convinced I'm able to seduce everything that surrounds me.
I want to breathe till I choke.
I want to love till I die.

What do you think of when you hear the word plastic?

—Literally, plastic means "capable of being shaped" and that's exactly what is my feeling when I approach a design in plastic. There's an expressive freedom that rarely happens with other materials.

What is your favourite colour?

—The rainbow.

Which Vondom item from another designer would you put in your home?

—When I go through the Vondom catalogue, I realize that it's full of designers friends of mine, so it's hard for me to choose only one.

What do you prefer, classic or science fiction movies?

—Since I chose Fellini as my spiritual mentor and with the very first money I made I bought an original photo of Fellini shooting on the set of 8 1/2 I guess I'd say classic.

Do you have any fetish object?

—My rings, I suppose.

What is the last thing you have bought?

—An artwork from an artist.

Do you believe in perfection?

—There's an idea of perfection related to the human body that in most religions defines the image of God. Let's say I prefer Goddesses, and that in all art history I follow traces of divine in the representation of the naked female body. From Courbet's "L'origine du monde" to my "HER" there's a common ground that can be defined as love.

Do you have any quirky habits?

—I am a total maniac! I'm lucky 'cause as a designer, people interpretates my fixations as creativity.

What do you do when you are not designing?

—I think I design even when I'm playing with my daughters.



f 3

F3 = Form follows function...

A collection based on mathematical surfaces that flow freely until reach the perfect function of each element. An apparently simple design that requires an accurate study of engineering and high precision, stackability concept never seen before in rotomolding.

COLLECTION BY F. **NOVEMBRE**



**SMART, BOLD,
AND PLUS
STACKABLE**

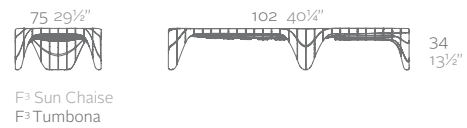

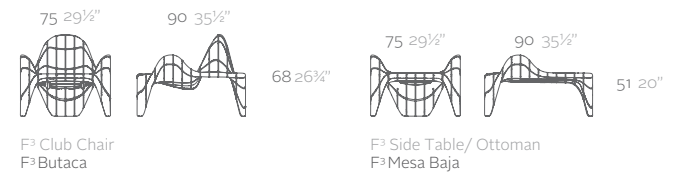
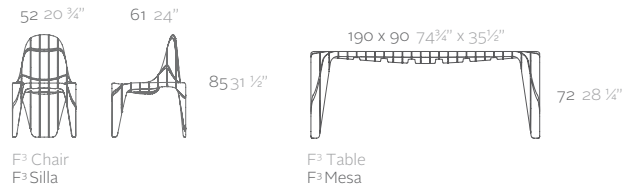

f^3

Through the various pieces of the collection manages to combine its aesthetic and functional Sculptural beauty lines that help us to flow from its shape. Mathematical Science became design.



BY F. NOVEMBRE

AND

AND is a spatial concept, a volume that cuts through the air, creating emotional turbulence for those who get swept up. AND is the result of two people looking at each other out of the corner of their eye, a multiplication into the infinite that includes anyone who simply wants to be there. AND is the reflection of the DNA of a generation that has embraced co-existence while denying tyranny.

AND: it's time for conjunction.



New Collection

DR. ROSS LOVEGROVE

The Wizard of Wales

"ROSS LOVEGROVE IS A DESIGNER AND VISIONARY WHO'S WORK IS CONSIDERED TO BE AT THE VERY APEX OF STIMULATING A PROFOUND CHANGE IN THE PHYSICALITY OF OUR THREE DIMENSIONAL WORLD. INSPIRED BY THE LOGIC AND BEAUTY OF NATURE HIS DESIGN POSSESS A TRINITY BETWEEN TECHNOLOGY, MATERIALS SCIENCE AND INTELLIGENT ORGANIC FORM, CREATING WHAT MANY INDUSTRIAL LEADERS SEE AS THE NEW AESTHETIC EXPRESSION FOR THE 21ST CENTURY. THERE IS ALWAYS EMBEDDED A DEEPLY HUMAN AND RESOURCEFUL APPROACH IN HIS DESIGNS, WHICH PROJECT AN OPTIMISM, AND INNOVATIVE VITALITY IN EVERYTHING HE TOUCHES FROM CAMERAS TO CARS TO TRAINS, AVIATION AND ARCHITECTURE."

Who really are you?

_The Worlds leader in advancing the relationship between FORM, TECHNOLOGY AND DESIGN.

What do you think of when you hear the word plastic?

_"PLASTIC" means retaining the fluidity and motion in inanimate objects.

What is your favourite colour?

_White.

Which Vondom item from another designer would you put in your home?

_Ora Ito's new collection.

What do you prefer, classic or science fiction movies??

_Almost Science FictionGRAVITY is an incredible visual experience and the future is mouldable not the past.

Do you have any fetish object?

_Yes I have some incredible African Tribal Fetish Objects such as Sexual Training Aids , one is half penis, half vagina , incredible.

What was the last thing you bought?

_A book on WATER by Ed Burtynski about 30 mins ago.

Do you believe in perfection?

_Yes its in everything I create industrially as perfection is achievable with modern technologies. Perfection is Industry /Imperfection is Craft.

Do you have any fixation or quirky habits?

_Good Question.....Im transfixed by sensuality and the need to move and be moved by the power of materials and form.

What do you do when you are not designing?

_I go as far back in time as I can to form a closed loop with the future.

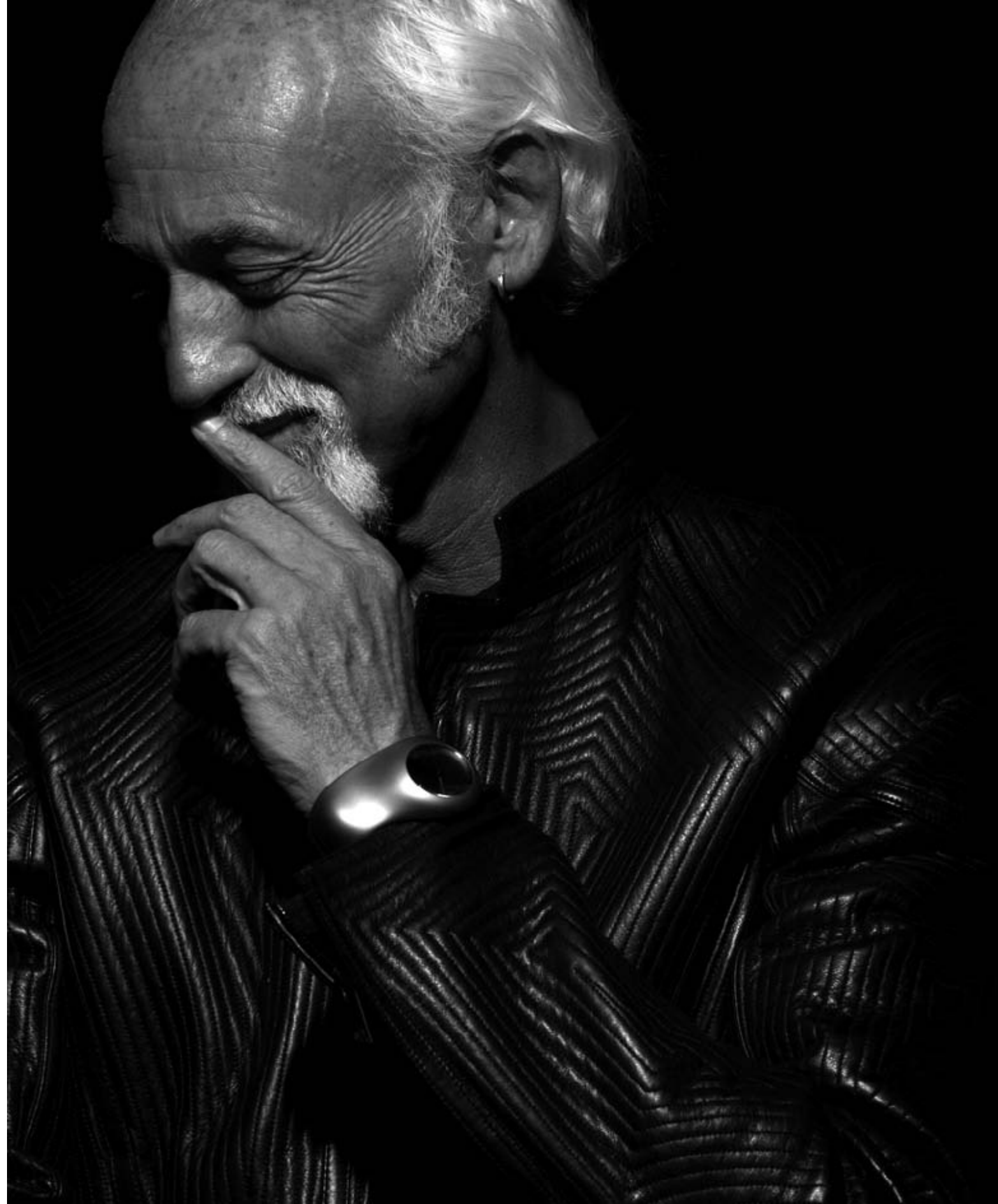

COLLECTIONS BY **ROSS LOVEGROVE**

BIO- PHILIA

BIOPHILIA Collection explores the a new design language that forms a dialogue between time, form and space combining the pioneering organic design of Sagrada Família by Antonio Gaudí, VONDOM expertise in advanced rotomoulded technology and my studios ongoing research into the transference of digital process into contemporary design.

Taken out of craft and into the 21st century progressive domain of polymerization and industry BIOPHILIA is a collection, acknowledges this lineage but pushes the boundaries between material structure and form into a new modern territory as yet unseen, parametrically conceived and diametrically opposed to modernism in its expression.

COLLECTIONS BY ROSS LOVEGROVE

BIO- PHILIA

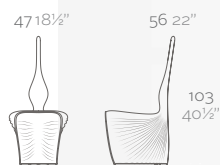

BIOPHILIA Chair
BIOPHILIA Silla



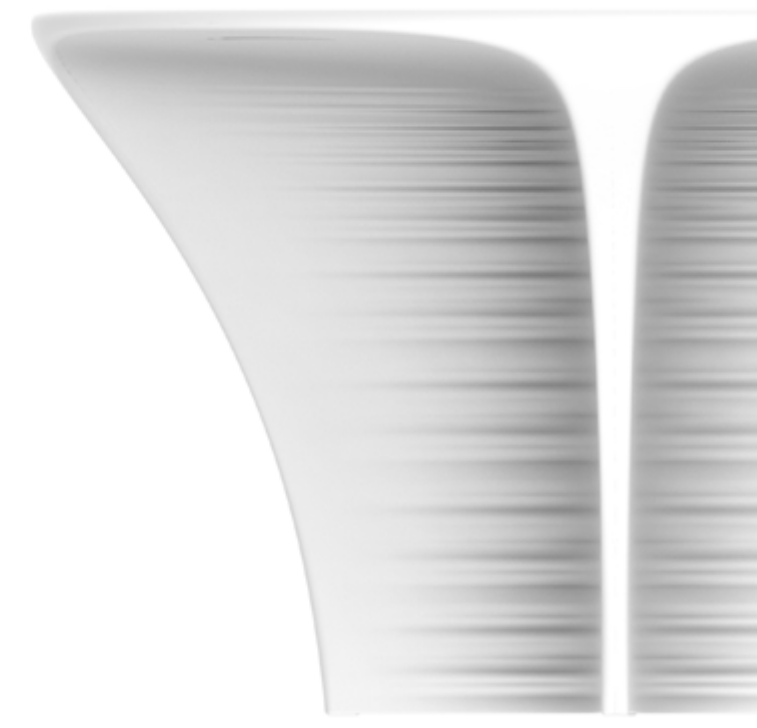
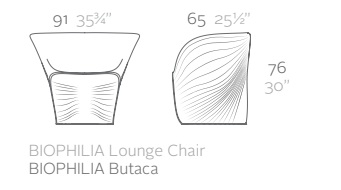
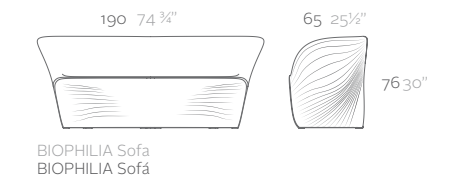
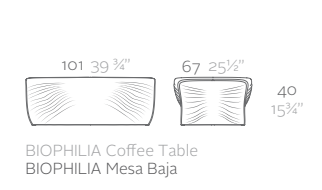

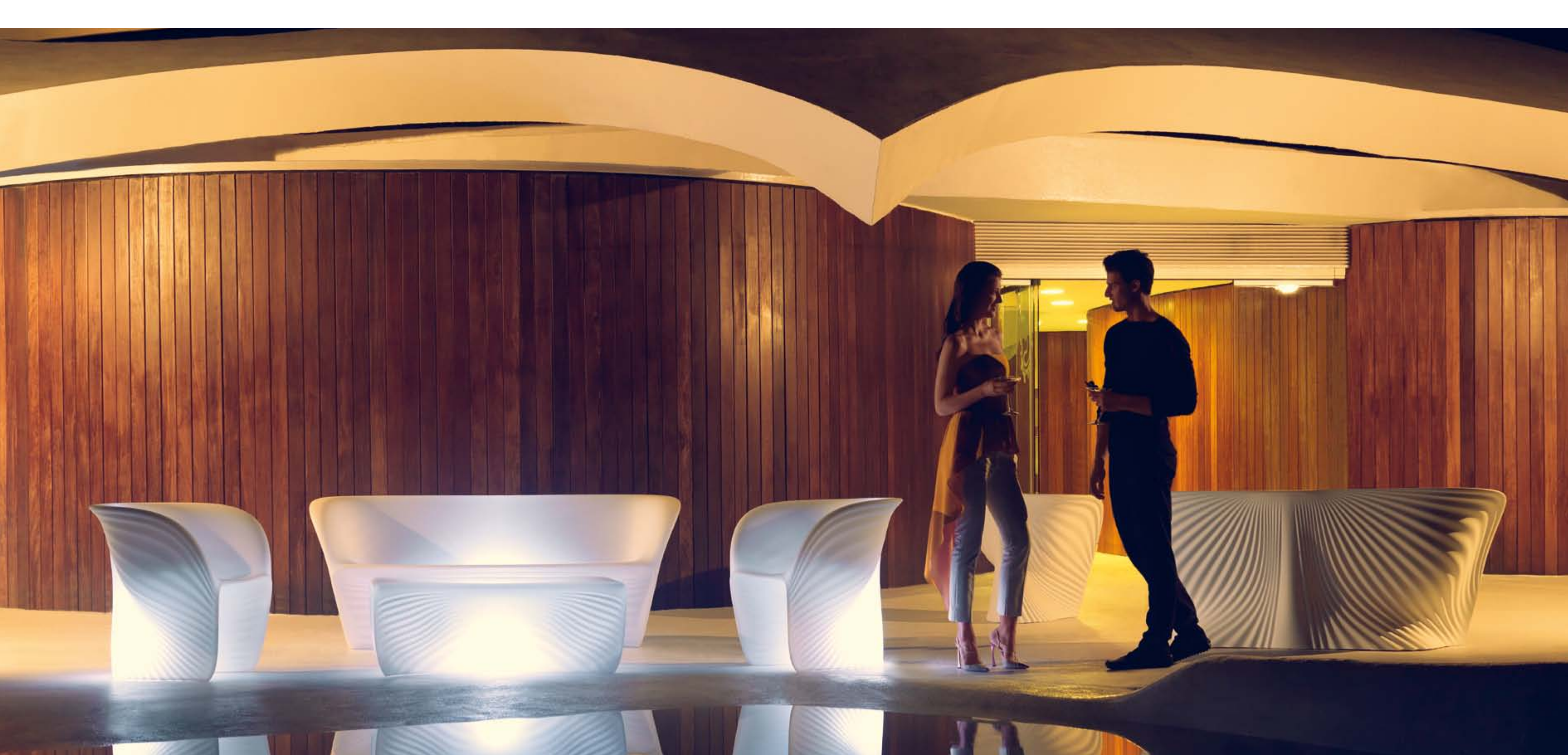



APPROACHING VONDOM
DESIGNERS / ORA İTO

ORA İTO

L'Enfant Terrible

"BORN IN 1977, THIS ICONOCLASTIC ARTIST BECAME GLOBALLY FAMOUS AT THE END OF THE 90'S BY HIJACKING IN 3D THE PRODUCTS OF THE MOST EMBLEMATIC AND INTERNATIONAL BRANDS SUCH AS VUITTON, APPLE, NIKE AND BIC ... FURTHERMORE THANKS TO NUMEROUS PUBLICATIONS IN THE PRESS, THE FICTION TURNED INTO REALITY. WHEN CUSTOMERS TRIED TO PURCHASE THESE IMAGINARY PRODUCTS, THE ORDERS FLOODED ORA-İTO'S WEB SITE. THIS BECAME THE SECOND DIGITAL WORK EVER ACQUIRED BY THE NATIONAL FUNDS OF CONTEMPORARY ART (FNAC). DURING THE YEARS 2000, ORA-İTO DEDICATED HIMSELF TO HIS OWN STUDIO AND THE CREATION OF REAL PRODUCTS, BY DEVELOPING TRANSVERSAL PROJECTS OF NEARLY ALL THE BUSINESS SECTORS OF DESIGN, ARCHITECTURE, COMMUNICATION, AND SO ON. HIS CREATIONS CONCEAL THE CODES OF A NEW LUXURY, TIMELESS AND UNIVERSAL WITH THE SAME MINIMAL WORKING DRAWING: EVIDENT FORMS TO BE UNDERSTOOD IN FLASH, FRUIT OF HIS PHILOSOPHY."

What do you think of when you hear the word plastic?

_ Lightness, freedom of shape, endless possibilities.

Which Vondom item from another designer would you put in your home?

_ Designs by Fabio Novembre and Ross Lovegrove.

What would you prefer, Vintage or Science Fiction movie?

_ 2011, a Space Odyssey by Stanley Kubrick, it has inspired all my work as I saw it when I was a child. Also I was born in 1977, the same year as the success of the Star Wars films.

Do you have any fetish object?

_ An open-hand sculpture by Le Corbusier.

What is the last thing you have bought?

_ A series of books at the Vasarely Foundation in Aix en Provence.

Do you believe in perfection?

_ Yes of course, It is what I'm searching for in all my projects.

Do you have any fixation or quirky habit?

_ Yes, the "Simplexité", is the word I invented to describe my work, the art to give to an object with complex functions a visible simplicity.

What do you do when you are not designing?

_ Not much I am always working !

DESIGNS FOR VONDOM:
UFO COLLECTION

COLLECTION BY **ORA İTO**

UFO

The collection results from "genetic mutation experiments" between the iconic languages of pagodas and UFOs. It is characterised by the opposition of negative and positive shapes. This creative approach gave birth to a Marta Pan inspired monolithic, fluid and sculptural line that encourages comfort and

relaxation. Its chair, table and sofa allow to create different compositions easily adaptable to outdoor spaces thanks to its elegant and resistant materials. The colors, range of finishes and interior lighting expands the possibilities to create different environments.



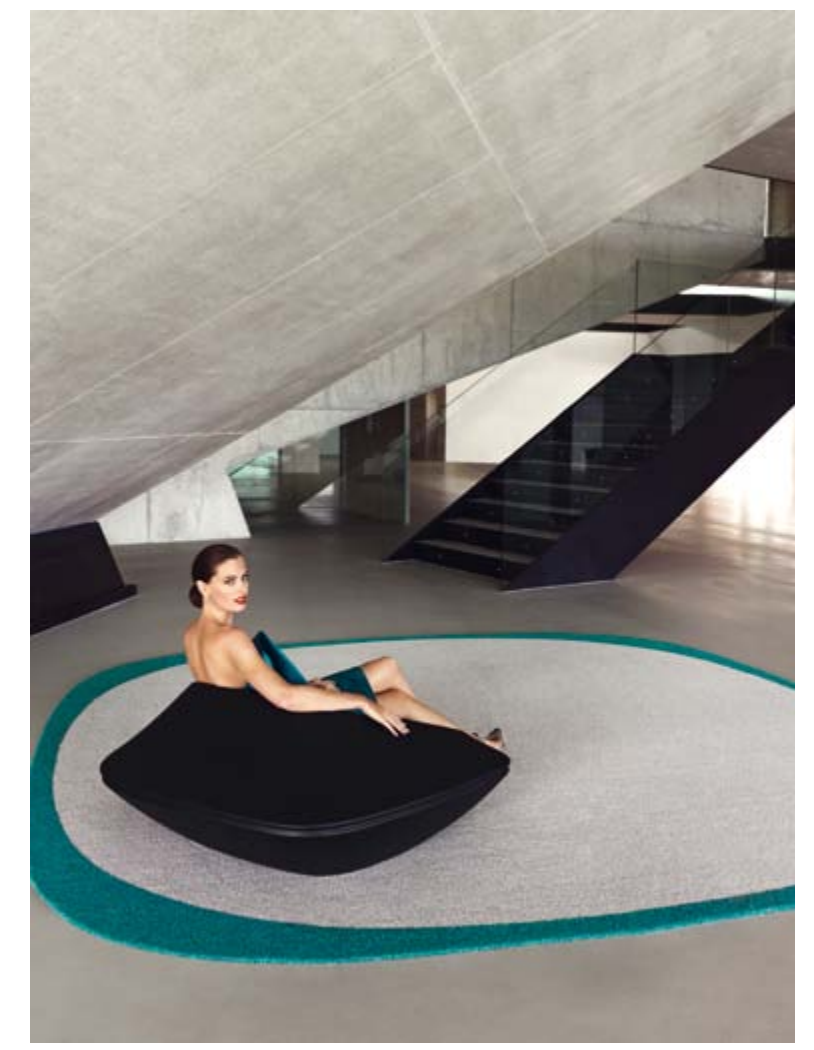
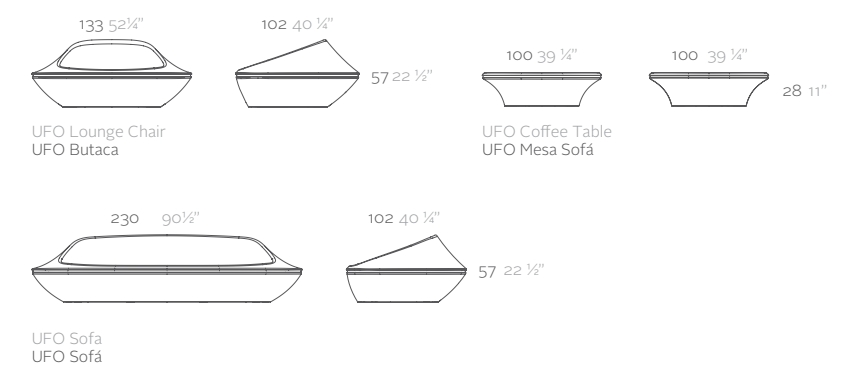



COLLECTION BY ORA ĪTO

UFO



EERO AARNIO

The Master

EERO AARNIO (BORN 21 JULY 1932 IN HELSINKI) IS A FINNISH INTERIOR DESIGNER, NOTED FOR HIS INNOVATIVE FURNITURE DESIGNS IN THE 1960S, SUCH AS HIS PLASTIC AND FIBREGLASS CHAIRS.

Aarnio studied at the Institute of Industrial Arts in Helsinki, and started his own office in 1962. The following year, he introduced his Ball Chair, a hollow sphere on a stand, open on one side to allow a person to sit within. The similar Bubble Chair was clear and suspended from above. Other innovative designs included his floating Pastil Chair (similar to a solid inner tube),^[2] and Tomato Chair (more stable with a seat between three spheres). His Screw Table, as the name suggests, had the appearance of a flat head screw driven into the ground. He was awarded the American Industrial Design award in 1968.

Aarnio's designs were an important aspect of 1960s popular culture, and could often be seen as part of sets in period science-fiction films.^[3] Because his designs used very simple geometric forms, they were ideal for such productions. Eero Aarnio continues to create new designs, including toys and furniture for children. Eero Aarnio opened his official webshop and first Design Eero Aarnio Showroom, in Helsinki. There you can find Aarnio's latest design, prototypes and latest news.

SOME AWARDS FROM AARNIO

Valmet Trade Mark Competition, Helsinki, Finland 1958, First Prize
International Furniture Competition, Cantu, Italy 1959, Third Prize
Export Furniture Competition, Helsinki, Finland 1963, Third Prize
International Competition on Furniture Design, Cantu, Italy 1964, First Prize
Scandinavian Park and Street Competition 1965, Stockholm, Sweden
Steel Furniture Competition, Helsinki, Finland 1967, Second Prize
International Design Award of the A.I.D. (American Institute of Interior Designers) for Pastil Chair (Gyro) 1969, New York, USA
Honorary member of SIO (Finnish Association of Interior Designers) 1999
The Finland Prize 2005, The Ministry of Education, Finland
Interior Innovation Award Cologne 2006, Germany
Eero Aarnio was awarded an honorary title of professor by the President of Finland, 2007.
The Compasso d'Oro Design award for Trioli chair, Italy 2008
Kaj Frank Design Prize in Finland, 2008
Red Dot Design Award 2010, for Kubo bright light, Germany
Pro Finlandia Medal 2010, Finland
Green GOOD DESIGN 2010, for The Tree, USA
Red Dot Design Award 2012, for Ghost lamp, Germany



10 SHORT QUESTIONS FOR...

Who really are you?

_A freelance designer since 1962.
(Please see my site www.eeroarnio.com)

What do you think of when you hear the word plastic?

_The word plastic suggests to me unlimited possibilities.

Which is your favorite color?

_White is my favorite color.

Which VONDOM item from any another designer would you place at home?

_I would like to have the WING collection, by A-cero at my home.

What would you prefer, Classic or Science Fiction movie?

_I prefer classic movies.

Do you have any *fetish* object?

_Nothing. I don't give any specific qualities or properties to any particular object.

What was the last thing you bought?

_I've just bought a snow shovel.

Do you believe in perfection?

_I believe in perfection in work.

Do you have any fixation or quirky habit?

_No, I don't have any fixations.

What do you do when you are not designing?

_I spend time with my wife Pirkko, I read, go for walks and in the summer we turn on the steam sauna.

PLASTIC PIONEER MASTER AND A LIVING LEGEND OF MODERN DESIGN. HIS NOW ICONIC PLASTIC CREATIONS INCLUDE THE BALL [1963], THE PASTIL [1968], AND THE BUBBLE [1968] CHAIRS WHICH ECHO THE POP CULTURE AND SPIRIT OF THEIR TIME. MANY OF AARNIO'S WORKS ARE INCLUDED IN THE WORLD'S MOST PRESTIGIOUS MUSEUMS, INCLUDING VICTORIA AND ALBERT MUSEUM IN LONDON, MOMA IN NEW YORK AND VITRA DESIGN MUSEUM IN WEIL AM RHEIN.



COLLECTIONS BY **EERO AARNIO**

ROULETTE

As Eero says, for all designers, the most common, interesting, and difficult object to design is a chair. Chairs for the home usually have four legs, stools have three, and office chairs have two or only one leg. Many plastic chairs don't have legs at all instead the body of the chair becomes the leg as well. When Eero started designing a chair for VONDOM, he had this concept of the leg being a part of the body of the chair in mind, and he also wanted to see what new could be accomplished with a rotation mold technique in chair design. Because he has

always been fond of rocking chairs and the round, rocking shape is easy to achieve with the rotation mold, he ended up with a design that rocks in all directions and also spins due to its contact with the ground at one point. The high armrests give a sense of security when spinning the chair around and also provide good support while sitting. He wanted to find an international name for the chair, which also would immediately give the association for the spinning movement, and that's why he ended up with the name "Roulette".



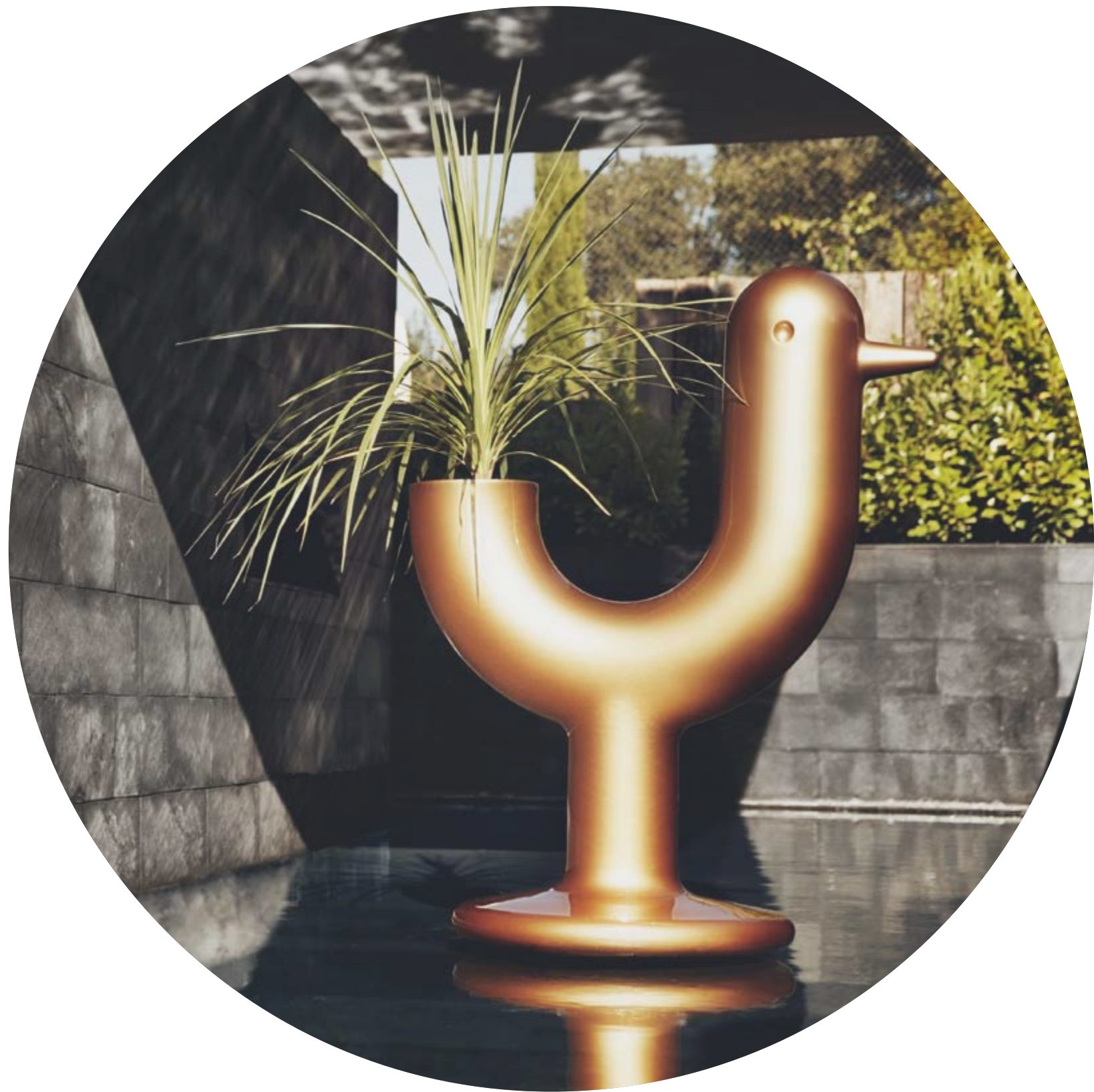

PEACOCK BY **EERO AARNIO**

PEACOCK



The master Eero Aarnio creates his first piece for VONDOM. It is without doubt a unique element for its amusing and symbolic design, Peacock Collection.

Just as its creator describes, the peacocks were part of his childhood, even though their country of origin is very far from Finland. Eero's home was very close to the Helsinki zoo, which is located on an island where the peacocks, which were imported from India,

were free to roam freely since they could not fly away due to their bad flying skills. The Peacocks in the zoo both fascinated and scared Eero, because when they fanned their tails they were bigger than him. Such memories are the inspiration of the creation of this new planter with much symbolism for Eero which naturally named "Peacock", thus emerging their "beak" with this figure of his childhood. VONDOM admires the iconic and timeless creations of Eero Aarnio.

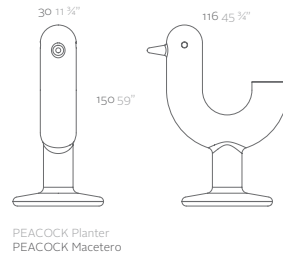

ROSI- NANTE- TE



ROSINANTE BY **EERO AARNIO**

Carousels and ferriswheels have always fascinated children and adults all over the world. This in mind I started designing a product which I haven't seen before: a rocking horse for adults and children. Traditionally a rocking horse only rocks back and forth, but this horse has a base which also enables us to spin. And because the horse is made in Spain, it was naturally named after Don Quixote's world famous horse, Rosinante. to outdoor spaces thanks to its elegant and resistant materials. The colors, range of finishes and interior lighting expands the possibilities to create different environments.

SOOOO!





APPROACHING VONDOM
DESIGNERS / ARCHIRIVOLTO

ARCHIRIVOLTO

Tuscan Good Life

CLAUDIO DONDOLI (*1954) - MARCO POCCI (*1953), ITALY. ARCHIRIVOLTO WAS FOUNDED IN 1983 BY CLAUDIO DONDOLI AND MARCO POCCI AS AN INDUSTRIAL PLANNING, DESIGN AND ARCHITECTURE STUDIO. WHILE STUDYING ARCHITECTURE IN FLORENCE, CLAUDIO AND MARCO AND SOME FRIENDS PUT UP AN EXPERIMENTAL THEATRE GROUP. WHEN THEY DECIDED TO FOCUS THEIR JOINT EFFORTS ON DESIGN, CONSOLIDATING THEIR TIES OF FRIENDSHIP, THEIR INTEREST IN THEATRE STRONGLY INFLUENCED THE SETUP OF THEIR NEW STUDIO, DRENCHED IN CREATIVITY, SENSE OF REALITY, RESPECT AND ATTENTION FOR THE PUBLIC.

Who really are you?

_Archirivolto design is very creative, devoting itself to all that the world has to offer in industrial design. Nowadays we are moving forward with architectural projects at an international level and have created a factory-farm that is combining design with the best Tuscany wine.

What do you think of when you hear the word plastic?

_ It's difficult for us to define something that for us is so essential, like bread and water. For us plastic is "The Material", it's flexible and inspiring enabling us to create what we want, how we want. It's true it's a man-made material but it's definitely close to nature. Nowadays it's also 100% recyclable. We could call it a "godsend", if you want.

What is your favorite color?

_ To choose a single colour is impossible. We need the full spectrum of colour, the rainbow, to live, but if we have to pick one, well then we would pick white for purity.

Which Vondom item from another designer would you put in your home?

_We would say that Vondom has a very wide selection and that the furniture is well co-ordinated but if we have to choose, without a doubt it would be "WING" by A-Cero. So light and inspiring, it's a must-have.

What would you prefer, Classic or Science Fiction movie?

_Science fiction for sure. We represent the future not the past.

Do you have any fetish object?

_Nothing in particular, but we are very close to "Oasis" (our factory-farm). If you can call that an object then it is our lifesaver.

What was the last thing you have bought?

_A good bottle of wine to celebrate the new Vondom Collection, including ours of course.

Do you believe in perfection?

_Perfection is a good word but as they say in Tuscany, "it doesn't belong in this World". We like to come as close as we can to it but we are imperfect beings.

Do you have any fixation or any quirky habit?

_ Let's see. Obviously design but we would also say "Le Bon Vivre" (The good Life).

What do you do when you are not designing?

_We try to anticipate future changes so as to know how to adapt harmoniously to this ever-changing world, so full of information and stimulation.

DESIGNS FOR VONDOM:
PEZZETTINA, FIESTA

COLLECTION BY
ARCHIRIVOLTO

PEZZETTINA

Pezzettina is a collection inspired by nature, a thought and a unique inspiration that materialize in an original product with fluid and expressive forms. Archirivolto Design has chosen for this new collection a creative concept away from the usual

geometry, rethinking and reinventing the ancient relationship with mother nature in order to build a renewed balance in our homes between nature and technology. A 100% organic design with elegant shapes through a 100% recyclable product.

New Collection

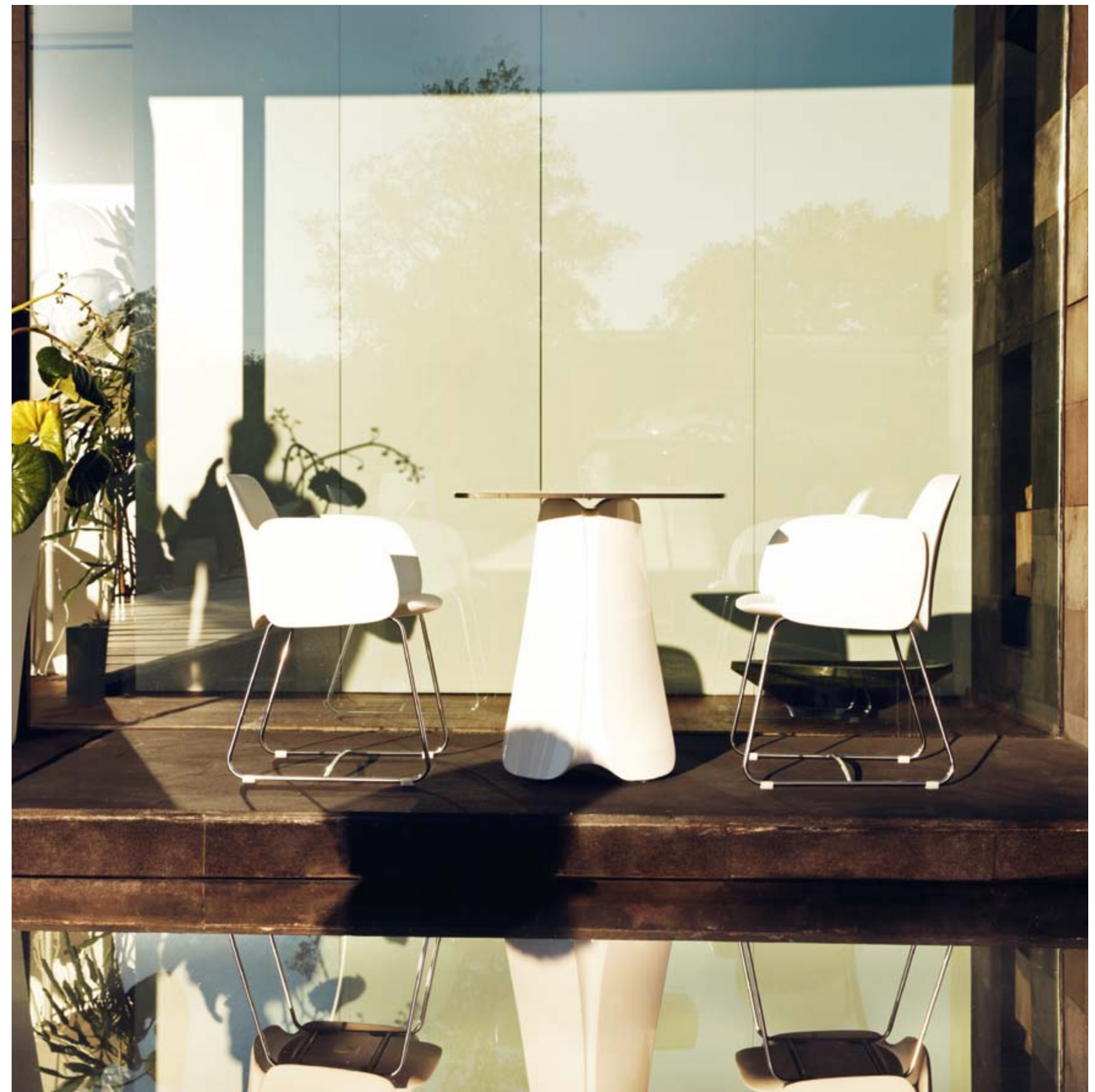

NEW LINE SOFT SHAPES

50 x 50
19 3/4" x 19 3/4"



50
19 3/4"

PEZZETTINA Planter 50
PEZZETTINA Maceta 50

65 x 65
25 1/2" x 25 1/2"



65
25 1/2"

PEZZETTINA Planter 65
PEZZETTINA Maceta 65

85 x 85
33 1/2" x 33 1/2"

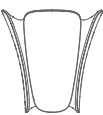

85
33 1/2"

PEZZETTINA Planter 85
PEZZETTINA Maceta 85

50 x 50
19 3/4" x 19 3/4"



85
33 1/2"

PEZZETTINA High Planter
PEZZETTINA Maceta Alta

58 22 1/2"



PEZZETTINA Armrest Chair
PEZZETTINA Silla

55 21 1/4"



80
31 1/2"



72
28 1/4"

PEZZETTINA Table 70, 80 or 90
PEZZETTINA Mesa 70, 80 o 90



NEW LINE SOFT SHAPES

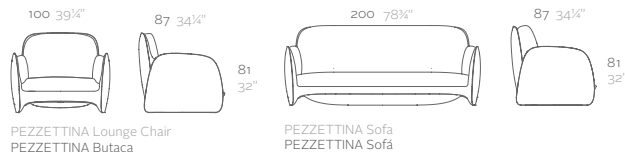
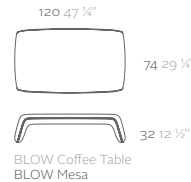

COLLECTION BY
ARCHIRIVOLTO

FIESTA

FIESTA is the new collection designed by Archirivolto for VONDOM; "design is beauty, harmony and freedom and cannot therefore be bound by strict, pre-established rules, nor can it only be seen as the privilege of social or cultural elite". It 's based in the entertainment places like that we can enjoy in summer holidays, for example, the beach. ... It's their function of entertainment places, with the beauty and the incessant mobility of waves, that let us get the inspiration for the bar FIESTA, with a simple and functional line, modular but also usable as a single piece.

A bar like this reminds us the freedom with which we lived the joyful days of our youth, when beaches weren't covered with people until the last grain of sand, where we could play football without provoking anybody to anger. In fact one of the shapes it can form it's the circle, always symbol of pureness, a recall to the ancestral shapes, devoid of useless frills. But on the contrary of this one, a fiesta is not eternal, ad what remains us to do is to keep it alive at least within ourselves, if only with the aid of a beautiful bar.



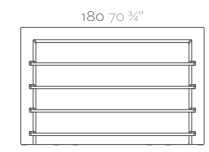

FIESTA Bar
FIESTA Barra

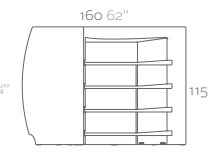

FIESTA Curve Bar
FIESTA Barra Curva

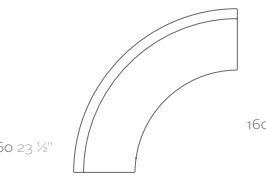
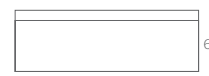



RAMÓN ESTEVE

"MEDITERRÁNEAMENTE"

RAMON ESTEVE GRADUATED IN ARCHITECTURE FROM ESCUELA TÉCNICA SUPERIOR DE ARQUITECTURA DE MADRID (ETSAM) IN 1990. HE FOUNDED RAMON ESTEVE ESTUDIO DE ARQUITECTURA IN 1991, WORKING ON BOTH ARCHITECTURAL AND INTERIOR DESIGN PROJECTS AND ALSO OTHER FIELDS SUCH AS INDUSTRIAL DESIGN AND ART DIRECTION AT THE NATIONAL AND INTERNATIONAL AREA. HARMONY, SERENITY AND ESSENTIALITY ARE SOME OF THE CONSTANT FEATURES OF ESTEVE'S WORK AND BECOME SYMBOLS OF HIS WILL TO PROVIDE TO THE HABITAT MORE THAN JUST BUILDINGS. AS A RESULT, EMBRACING ATMOSPHERES WHERE TO ENJOY UNIQUE EXPERIENCES ARE CREATED.

Who really are you?

_I'm someone who encourages everything related to beauty and intelligence.

What do you think of when you hear the word plastic?

_It's the magical materia. It's a liquid material. It can be used for the most trivial objects, or by design can be changed into the most glorious objects. It's possibilities are only limited by your imagination.

What is your favourite colour?

_I have an affinity to natural colours and tones. But I like all the colours depending on the context. I usually dress in black, everything in my home is white, but in my projects I can play with daring colours with no fear at all.

Which Vondom item from another designer would you put in your home?

_I couldn't choose one piece, all VONDOM designs have great quality, but I must admit a weakness for the simple natural forms by Stefano Giovannoni.

What do you prefer, classic or science fiction movies?

_I like the cinema too much, it's one of my passions and I find it impossible to choose one film. Today I would choose Blade Runner, by Ridley Scott as science-fiction and as vintage Manhattan, by Woody Allen, a great filmmaker, doing good comedy is only available to a few geniuses.

Do you have any *fetish* object?

_I'm not a collector, I enjoy a good object, but I don't idealize it. Really I don't keep anything in my house, it's very empty of objects. My friends joke that I live in a Cistercian cell.

What was the last thing you bought?

_I love fashion. I bought shoes by Prada (another of my little weaknesses)

Do you believe in perfection?

_Yes, I think perfection is in simple things.

Do you have any fixation or any quirky habit?

_Yes I suppose I have too many. With any other career it would be a serious problem, but in my case perhaps it helps when I am designing things. When you are creative no one puts limits but you have to put them yourself. In order to play you have to create the rules.

What do you do when you are not designing?

_I enjoy what I do everyday. I never stop thinking about my work and all that relates to it, it's what keeps me alive. I have some hobbies that I try to do daily: Books, history, films, and as every good person from the Mediterranean area I'm passionate about food.

INSPIRED BY
NATURAL
SHAPES

FAZ

COLLECTION BY RAMÓN ESTEVE

COLLECTION BY
RAMÓN ESTEVE

FAZ

Ramón Esteve, architect of the harmony, serenity, timelessness and the universality has created mineral and expressive shape that makes FAZ a design that contextualizes with the homes and installations. Atmosphere, encircling as a result of the happy combination of the material and light elements, so that the unique sensing would be its fusion. Their soul VONDOM lives themselves in the exclusiveness by the quality of the material that permits an exterior using even in the most exacting environments. The modularity of FAZ permits the consumers to adapt the furni-

ture and flowerpots to their style and necessary without losing the harmony of this furniture set. FAZ is composed by a sun-lounger with auxiliary table, armchair, modular sofa and coffee table. Complete the collection with three flowerpots of different proportions that form a unit. The collection is available with excellent quality nautical or polyester cushion. The result is a work that transmits essence, that contains the complexity and the density of a resolved work until the extreme detail, whose end is the creation of places where desire to live.

New Collection

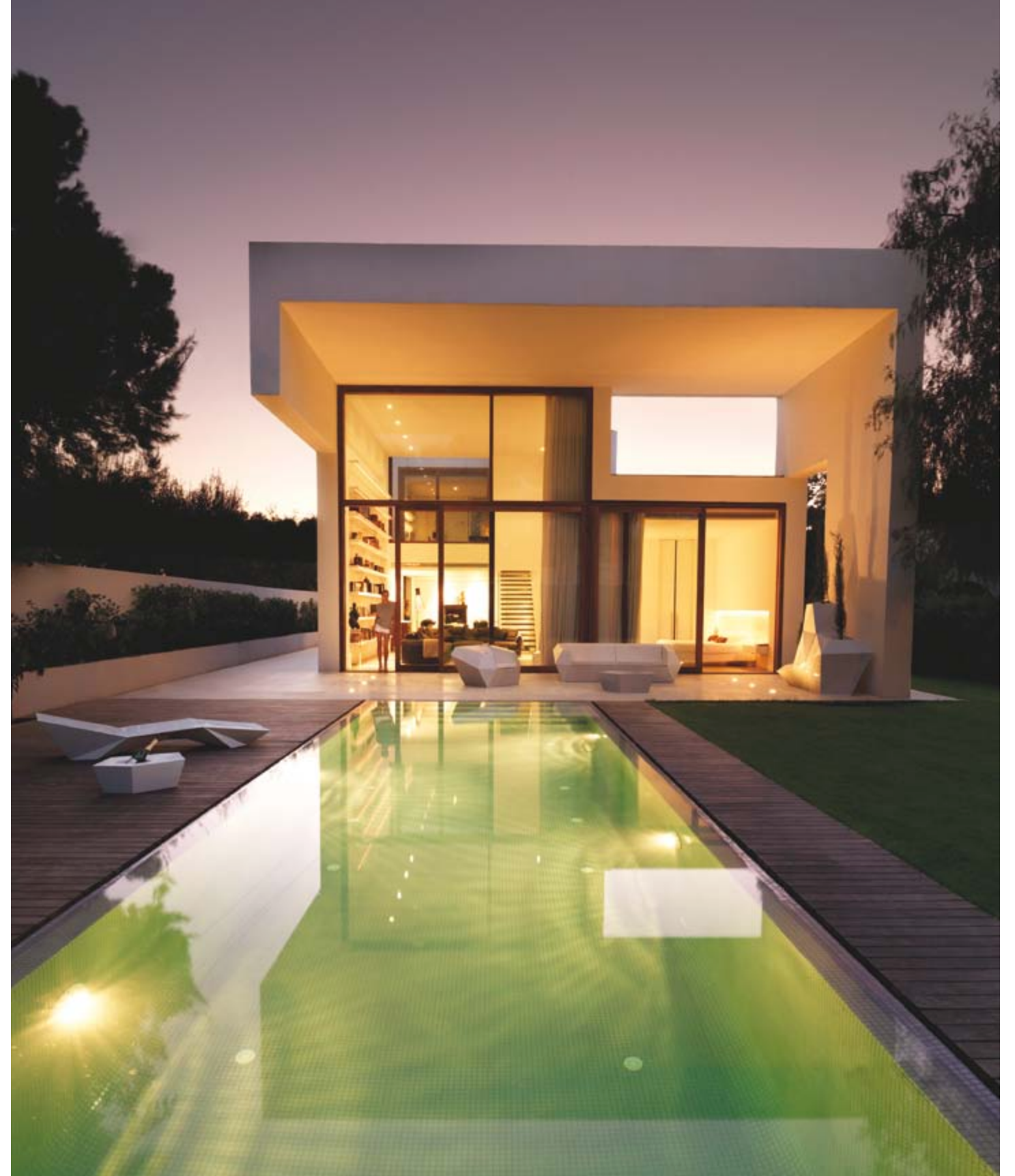



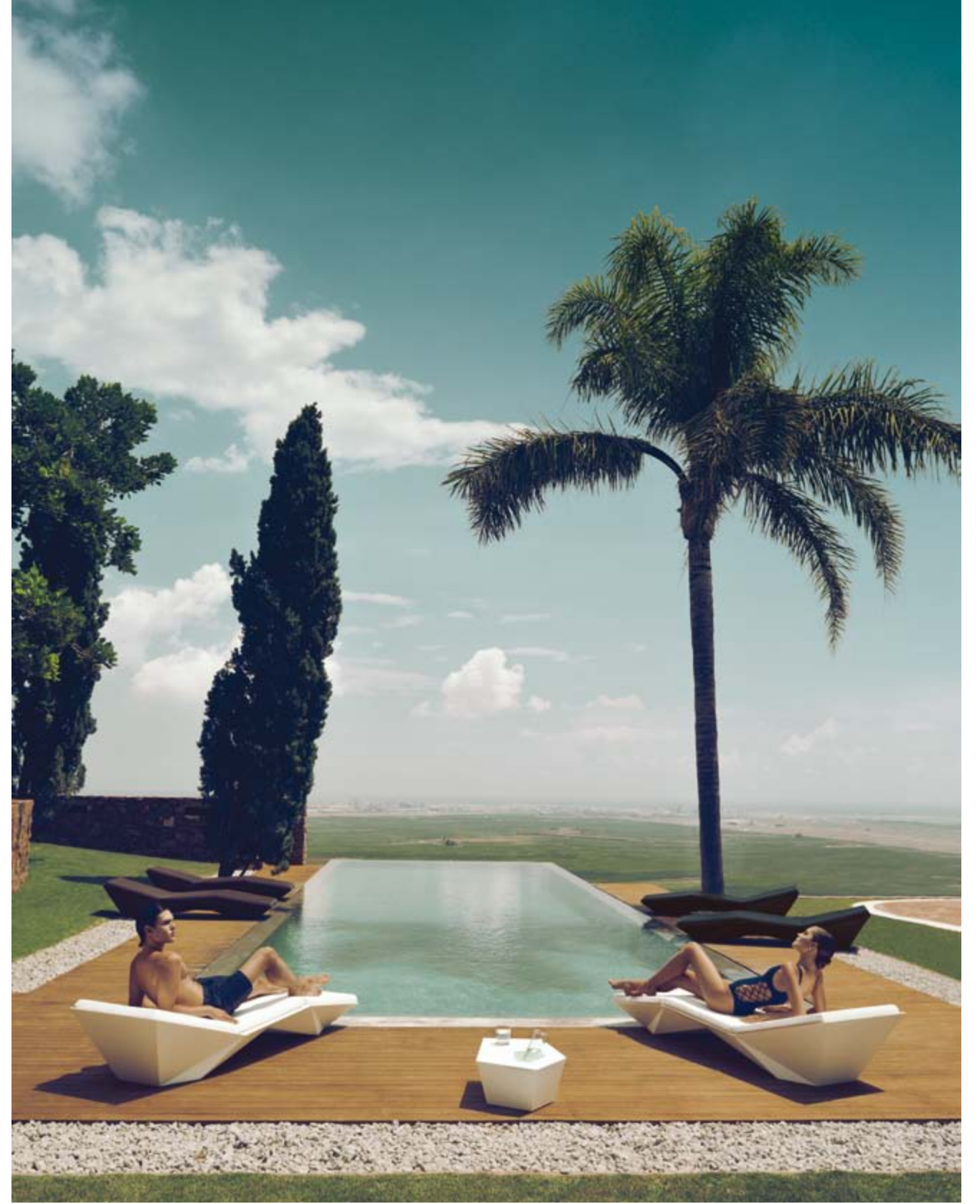

INSPIRED BY
NATURAL
MINERALS



New colors





NEW LINE NEW SHAPES FAZ

New Item FAZ

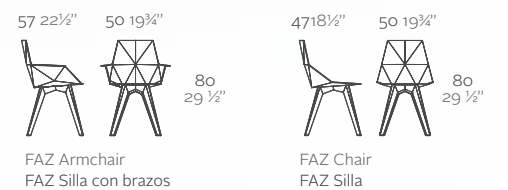
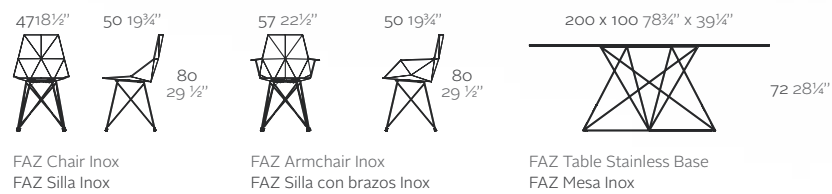
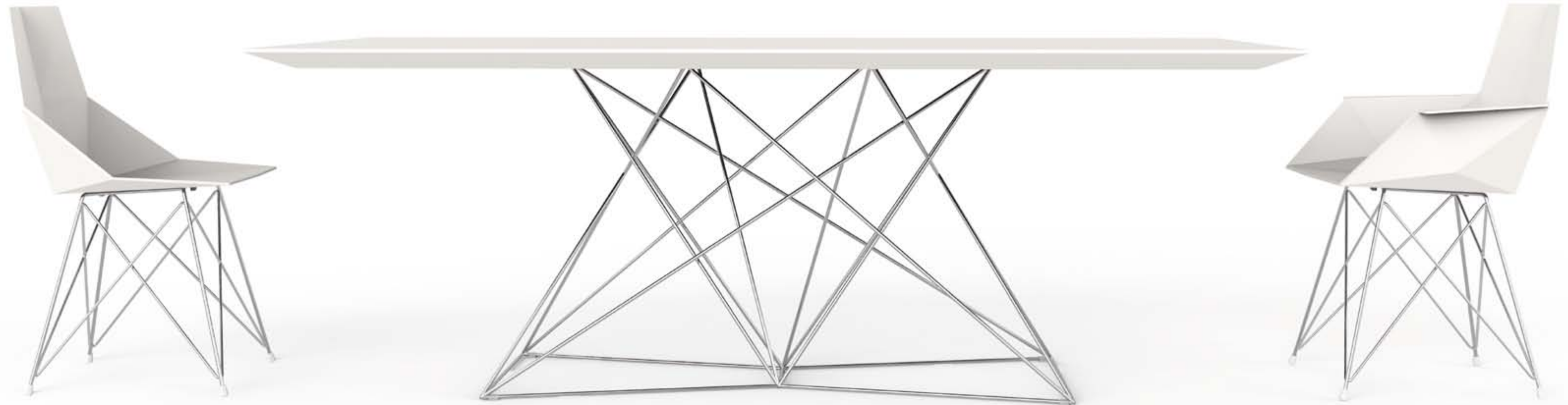



FAZ, COS
LIFE IS SO
MAGIC



THE ICONIC PIECE DAYBED FAZ

As the other models of FAZ Collection, is inspired in the mineral forms that we could find in the nature, it recalls the figure of the crystallized quartz. Daybed Faz becomes a must for the day and for the night with Batyline® technology for its distinctive umbrella and sunshade system. It also has outdoor sound system, through which you can enjoy an exceptional sound quality by simply connecting a Smartphone or via Bluetooth technology. A highly weather-proof system which you can create enveloping atmospheres.

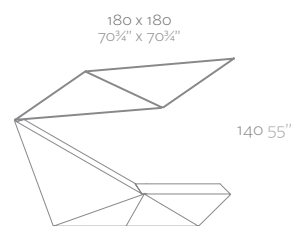
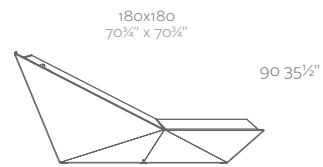

FAZ Daybed



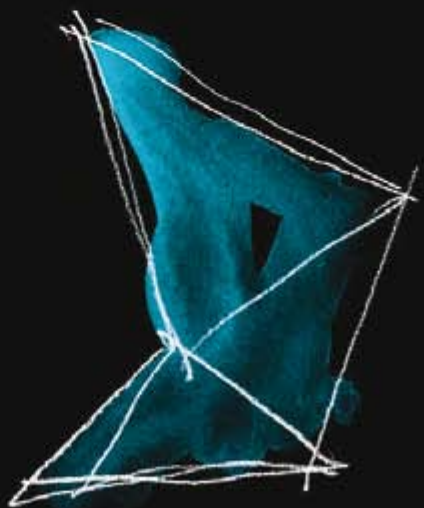
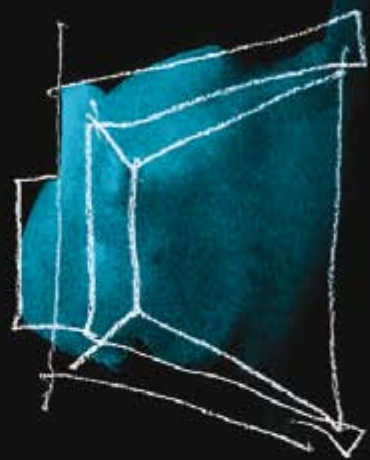
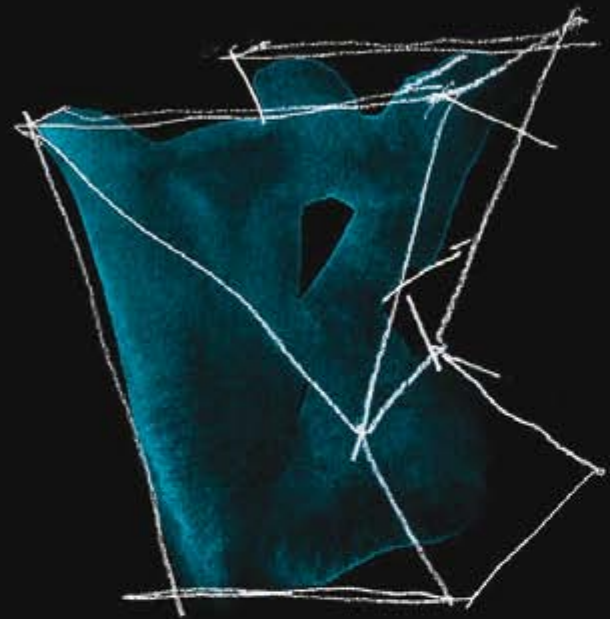

86 3/4"



74 29 1/4"



220 86 1/2"

FAZ Lamp
FAZ Lámpara

COLLECTION BY
RAMÓN ESTEVE

VELA

This extensive outdoor furniture collection looks to offer the comfort and the quality of the interior furniture without losing its characteristic of origin. VELA is a modulate system with a geometric prismatic element that bases its singularity in the balance of its proportions. The elements can combine among themselves to integrate in any space. Their flat volumes give the illusion to float to some centimeters

of the floor and when they are illuminated they are transformed into light architectures. It is manufactured by rotational molding with lineal low density polyethylene. It is a 100% recyclable material that supports extreme climatic conditions, from -60°C to 80°C, as well as resistant to the UV rays and present the lightness to the product. VONDOM offers this collection in matte, lacquered or colored finished and is ready to incorporate light.



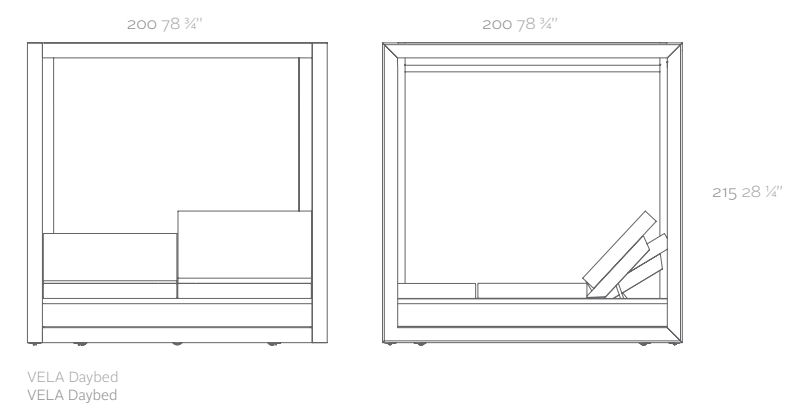

THE ICONIC PIECE DAYBED VELA

Daybed Vela is the new member of the family Vela, a unique piece is high light for its originality and versatility. It is a double beds with mobile back, the two users can relax with lifted support toward the same direction or opposite to one another, while the hollow of the center becomes an elegant bottle holder to serve champagne, wine ...



**VELA POOL
FEEL THE
SUN**



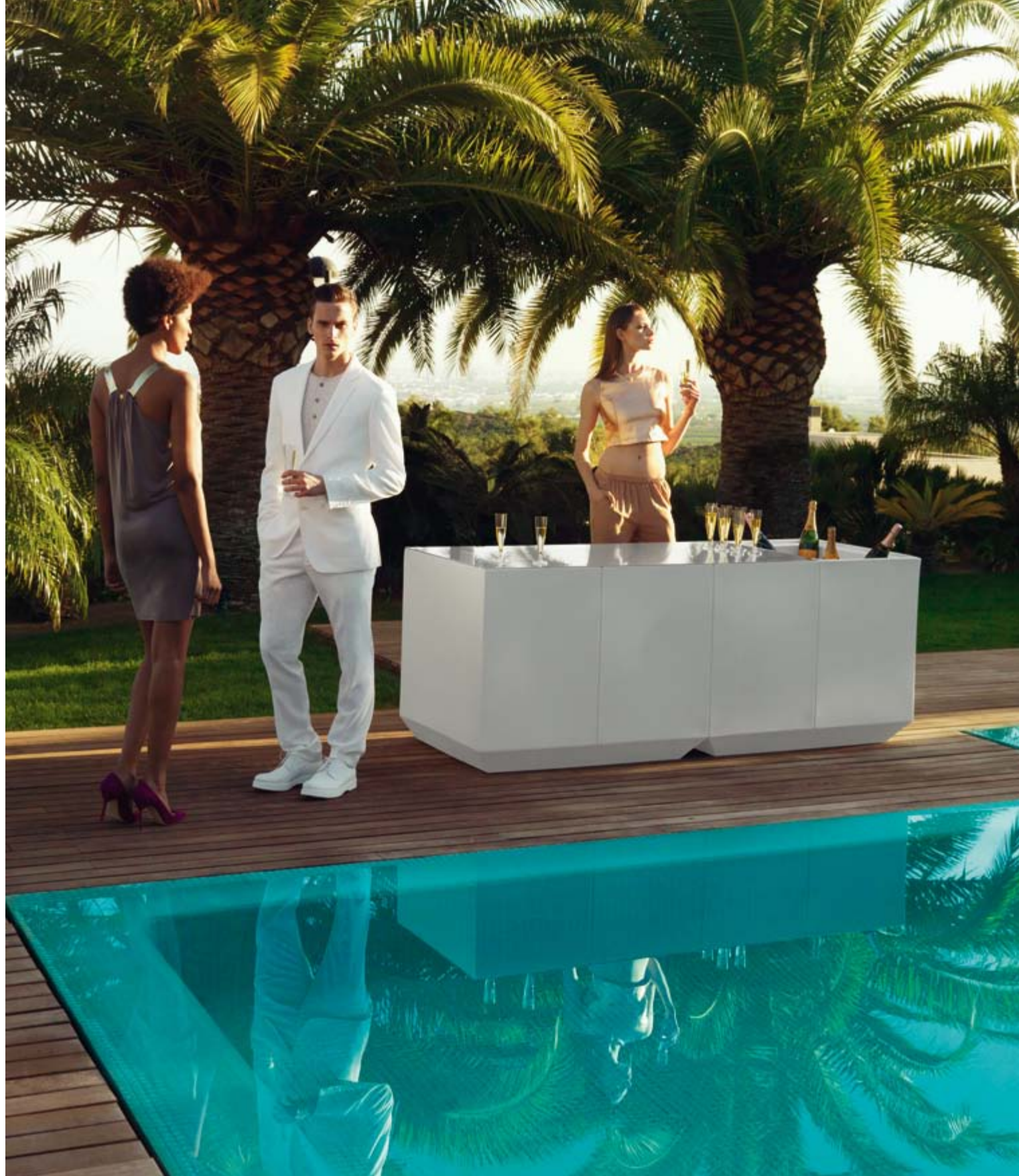

VELA NEW ARRIVALS



**VELA SET
ENJOY THE
NIGHT**

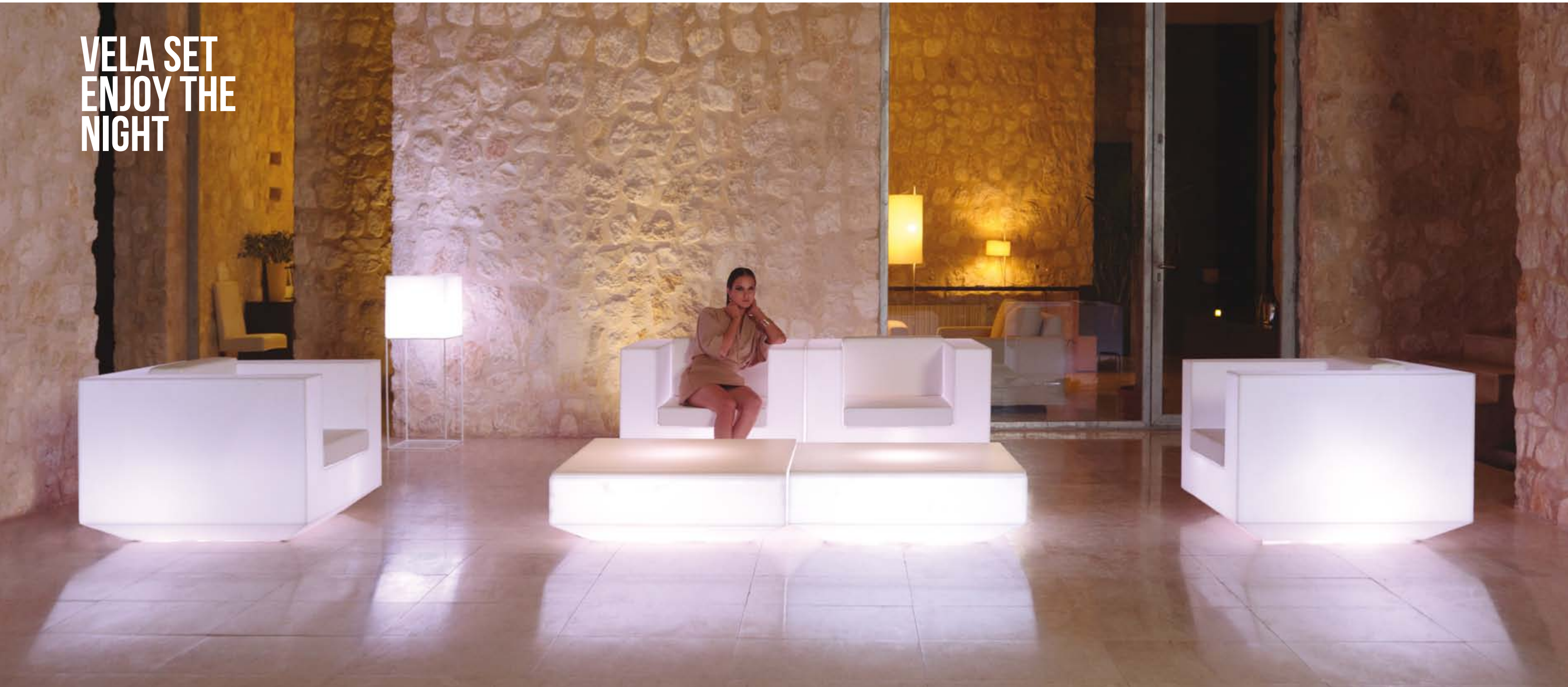

VELA CONTRACT ATMOSPHERE

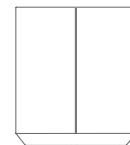
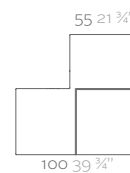

VELA Corner Bar
VELA Barra Esquina

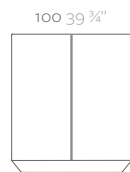

VELA Door
VELA Puerta

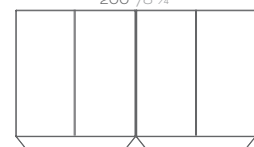

VELA Double Bar 200
VELA Barra 200



VELA Single Bar 100
VELA Barra 100

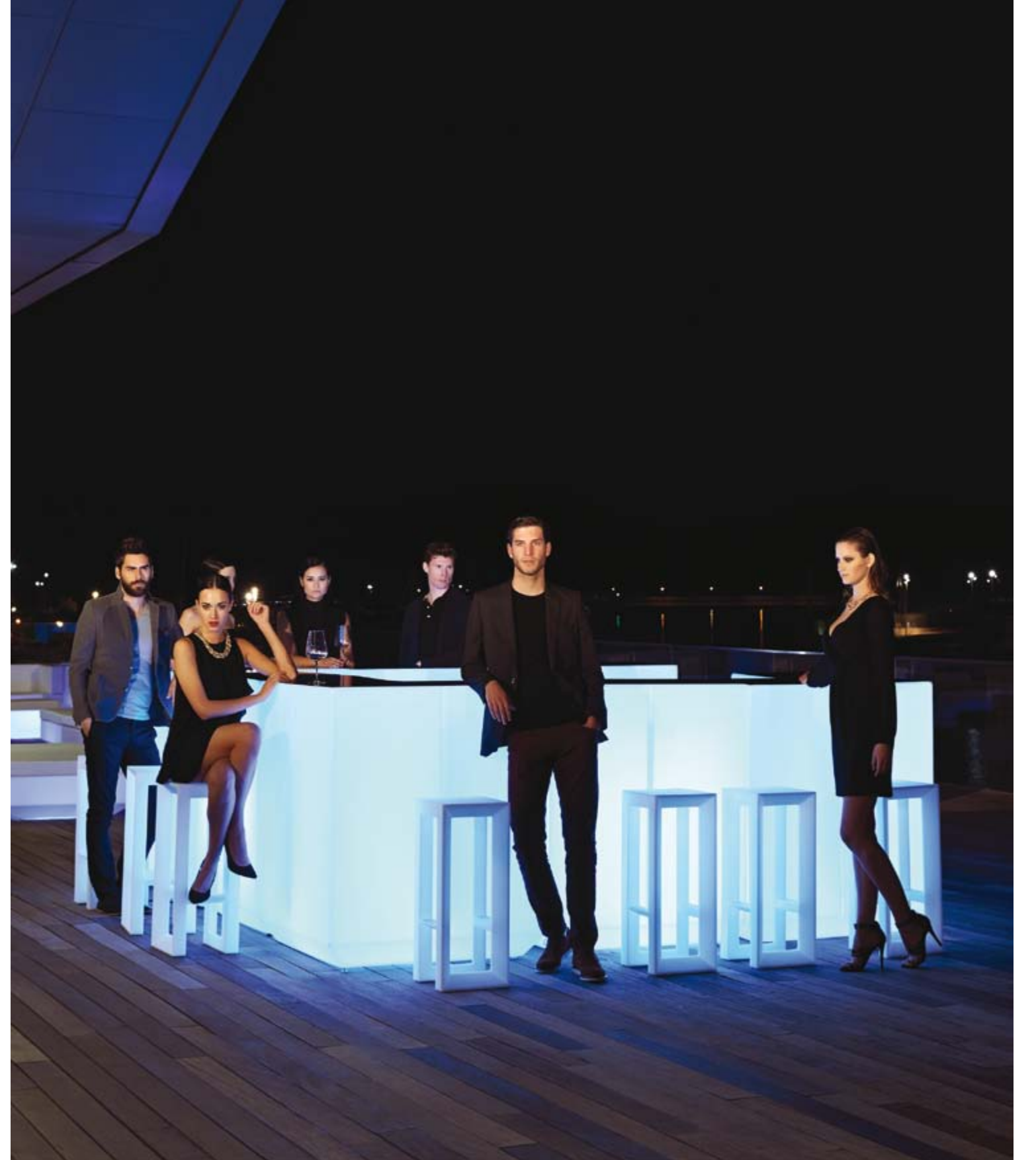

COLLECTION BY
RAMÓN ESTEVE

FRAME

FRAME Collection comes from generating serene and timeless shapes using the framework as elementary geometry. The endless possibilities offered by the material using advanced technology, was the motivation to explore the limits. The FRAME section is flared creating pieces of visual lightness while still categorical and resistant. FRAME meets a wide range of needs in any

outdoor space thanks to its variety of pieces. The collection consists of high and low stools, benches, chairs, modular sofa, tables of various sizes, chairs and chaiselongue. The lightness of the pieces such as the armchair and chair are stackable. The chaiselongue has a reclining backrest and wheels built in the framework for a better displacement.

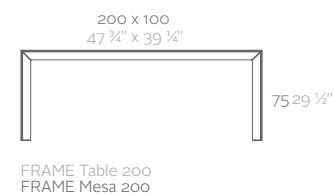
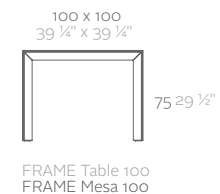
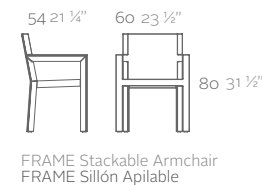
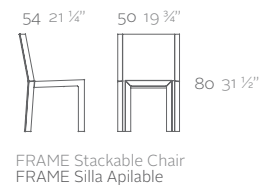
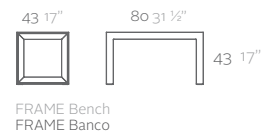
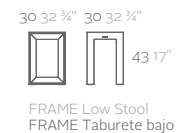

FRAME RAMÓN ESTEVE WHEN BEAUTY IS A SIMPLE THING

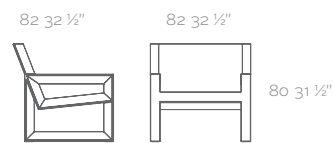

FRAME Lounge Chair
FRAME Butaca



FRAME Ottoman
FRAME Puff



FRAME Coffee Table
FRAME Sofá Mesa

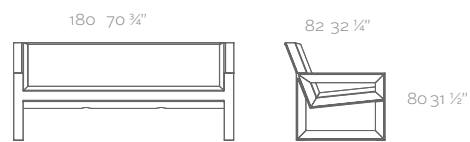

FRAME Sofa
FRAME Sofá



FRAME Sun Chaise
FRAME Tumbona



FRAME Table Sun Chaise
FRAME Mesa Tumbona







KARIM RASHID

the Pinkaddict

Who really are you?

_I am a design pervert, cultural shaper, poet of plastic, digipop rockstar.

What do you think of when you hear the word plastic?

_Plastic has always been important to me. I saw it as the lively, energetic material of all materials. It was the glossy one, the smooth one, the transparent one, the glowing one, the soft and touchy one, the recyclable one, the fluid liquid solid, and the lightweight material that I, as a young child, naively knew was the material of our contemporary world.

What is your favourite colour?

_I love pink and techno colors- colors that have a vibrancy and energy of our digital world. There are really millions of colors so it is ridiculous in this life to have a single favorite of anything- favorite song, favorite book. The beauty of this farrago in life is the broad diversity and choice of everything. I love color and I am not afraid of it. I use it in a painterly way as a way of driving emotion through our physical object's our spaces, to expression motivate, to inspire, and question, to challenge, and touch or evanescent public memory.

Which Vondom item from another designer would you put in your home?

_The Biophilia loveseat from Ross Lovegrove. I have long been friends with Ross and I greatly respect his work and how it pushes the boundaries of technology, software, and speaks about the digital age and natural form.

What would you prefer, Classic or Science Fiction movie?

_I would direct, write and act in my own Sci-fi screenplay. The movie would be called THE PINKARIM and it would be a futuristic science fiction that portrays the future as the most beautiful place. In fact I've already worked on visualizations, renderings and sketches for animation. Designers must evolve society forward, not backward.

Do you have any *fetish* object?

_Everything I design is a fetish object for me.

What was the last thing you bought?

_I just bought the Jawbone Up. I love it. It monitors your heart rate, works as a pedometer, and wakes you up using your body's natural circadian rhythms and I bought a vase that Alessandro Mendini designed (my mentor).

Do you believe in perfection?

_I believe it is something to strive for, whether attainable or not. My life must be very organized, minimal yet sensual, simple, and I strive for perfection always. to be.

Do you have any fixation?

_Yes, Beautifying the world, and creating well designed, provocative, stimulating yet calming products and environments is the impetus for everything I embark on. It is my worldly goal. With all my work, whether it is a perfume bottle or a restaurant or a laptop I am interested in creating new languages, in speaking about our technological world, and about communicating the time in which we live. It is important for me to not just decorate or embellish but to make objects or places that elevate and inspire the user. The role of a designer today is to make the world a better place through increasing our everyday behaviors, functionally and emotionally. By replacing the clutter of poorly designed and poorly made objects, with beautiful high performing objects, hopefully sustainable, ergonomic, well-made, sensible yet seductive objects, we reduce the stress in our environments and in everyday life.

What do you do when you are not designing?

_Well design is my life so it is basically inseparable from my being, but I like to compose electronic music, deejaying, and love running and exercising every day and eating a strict organic diet. Also I enjoy cooking when I have time and of course spending time with my wife and our beautiful baby girl, Kiva.



"KARIM RASHID IS AN INDUSTRIAL DESIGNER AND INTERIOR ARCHITECT. HIS DESIGNS INCLUDE LUXURY GOODS, FURNITURE, LIGHTING, SURFACE DESIGN, BRAND IDENTITY AND PACKAGING. TIMES MAGAZINE HAS DESCRIBED HIM AS THE "MOST FAMOUS INDUSTRIAL DESIGNER IN ALL THE AMERICAS... IN HIS SPARE TIME KARIM'S PLURALISM FLIRTS WITH ART, FASHION, AND MUSIC AND IS DETERMINED TO CREATIVELY TOUCH EVERY ASPECT OF OUR PHYSICAL AND VIRTUAL LANDSCAPE." KARIM RASHID IS ONE OF THE MOST PROLIFIC DESIGNERS OF HIS GENERATION. OVER 3000 DESIGNS IN PRODUCTION, OVER 300 AWARDS AND WORKING IN OVER 40 COUNTRIES ATTEST TO KARIM'S LEGEND OF DESIGN.

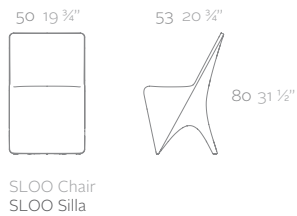

CAPSULE COLLECTION BY **KARIM RASHID**

SLOO

Sloo creates a state between liquid plastic and solid material object. Plastic loves to flow, to be amorphous. We too are amorphous so the relationship is symbiotic. The results are organic forms that softly translate into and out of flat planar surfaces. The overall feeling creates a state of endlessness, a continual ephemeral experience. Its material let using in outdoor and indoor, as the polyethylene resin is highly resistant to impacts and extreme temperatures. Its wide range of finishes and colors allows the creation of different spaces easily.

Sloo Chair collection of Vondom, designed by Karim Rashid, wins a Good Design ... company, Vondom, has been recognized with a Good Design Award 2013.





WOOD
TABLE LEGS
FEEL SO
TRENDY

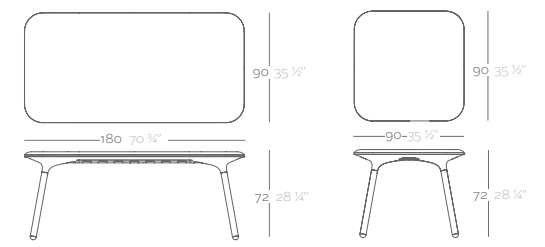

SLOO Table 180
 SLOO Mesa 180

SLOO Table 90
 SLOO Mesa 90

POT COLLECTION BY **KARIM RASHID**

KANNELLONI & SPAGHETTI

SPAGHETTI

Is a new planter designed by Karim Rashid for VONDOM. The SPAGHETTI planters evoke a lightness and duality that speak of the combination of materials. For Karim, VONDOM is a wonderful company to work with for their interest in developing ideas that are not only rotationally molded but combine other materials. The idea is to monumentalize the plant, to raise it from the ground, to have less mass using a skeleton support that suspends the volume in space.

KANNELLONI

The KANNELLONI planters have a minimal design and a pure geometric form that is versatile in its placement. While designing the KANNELLONI family Karim found it necessary to focus on a form that would fit the most modern of spaces, it could sit on a window sill, wall or step, and still be a commercial product that could be specified widely in the contract market. So you can take KANNELLONI and stuff it with soil, and have a beautiful garden in your home, office, or by the pool.

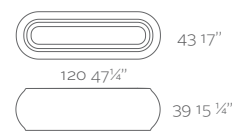

KANNELLONI Planter 120
KANNELLONI Maceta 120

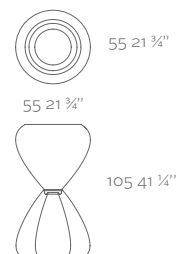

SPAGUETTI Planter Ø55
SPAGUETTI Maceta Ø55



SPAGHETTI



KANNELLONI



BY **KARIM RASHID**

VERTEX

One of the latest great works by KARIM RASHID, we can find it in VERTEX, a family of ultra-contemporary sculpted outdoor & indoor furniture designed for the Spanish brand VONDOM. Vertex, a set of table and chairs, its triangular planes meet dynamically to create comfortable forms suitable for dining, meeting rooms, banquet, lecture halls and other casual needs. VERTEX looks as if it was chiseled from a single block of material, what is left is structural yet, beautiful.

The collection VERTEX is created for integrating into our space a more conceptual architectural piece, to give it a more sophisticated touch. The pieces are manufactured by rotational molding, the main characteristic of this technique is that the material is 100% recyclable and it can explore never-ending possibilities in the shapes.

**NOT
FROM
THIS
WORLD**



COLLECTION BY
KARIM RASHID

DOUX

DOUX, a collection of different pieces derives directly from the pen sketching freely: organic, spontaneous, friendly, and colorful. The zoomorphic forms are to engage, to touch, to sit, to enjoy.

Exclusive pieces are manufactured by the rotational molding technique. The versatility & dynamism are the most standing out elements of this collection. One of the peculiarity of this product family is the multifunctionality of the table - when laying down, it carries out the function as table and there has a hole works as room for storage; when raising up, the hole used as flower pot or as a cool ice-tray for champagne or wines etc.

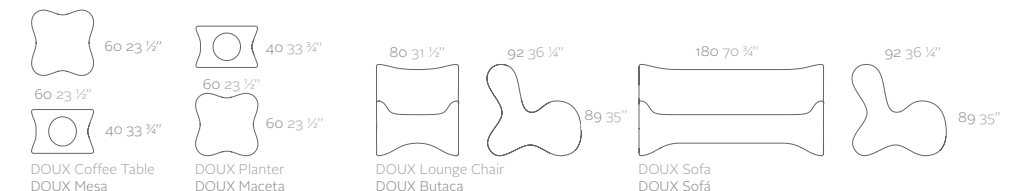

BY **KARIM RASHID**

SURF

The flowing wave that composes the seat and leg rests of SURF alludes to a sense of calm. It is a soft swell in lux, a fluid gesture that changes to vary light. The method of its creator is the overriding canvas of the world for a new well-being that evokes calmness, casualness, driven by vibrant forms that are refreshing, awakening, and elevating and are metaphors for a new global dynamism.

The pieces are manufactured by rotational molding, the main characteristic of this technique is that the material is 100% recyclable and it can explore never-ending possibilities in the shapes.cushion. The result is a work that transmits essence, that contains the complexity and the density of a resolved work until the extreme detail, whose end is the creation of places where desire to live.





DYNAMIC LIGHT & SEXY

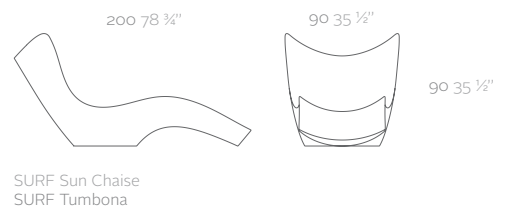

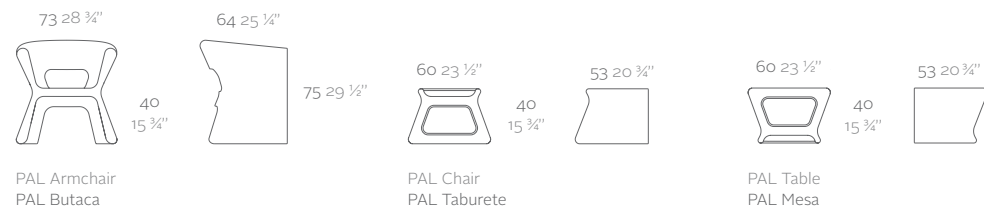

CAPSULE COLLECTION BY **KARIM RASHID**

PAL

The minimal iconic shape at the front of the object is revolved around, keeping a constant flow of similarity between the different objects of this collection.

The PAL stool is multi-functional - there is room for storage and when it flips over it becomes a small side table then placed together with a second become an even larger coffee table; there has a hole in lateral plan works as room for storage.





BY **KARIM RASHID**

LAVA

OR HOW TO TRANSFORM A BENCH IN A SCULPTURE

Lava is a unique experience of beauty, luxury, performance and functionality seamless together. LAVA, is an undulating, cloud-like bench, a really huge organic blobular sculpture which is very difficult to obtain with the manufacturing process such as rotomoulding technique. LAVA, its avant-garde and original shape creates a pleasant, natural and relaxing

gathering spot or connection in any interior & exterior space. For giving a more special touch in mentioned space, we can obtain it integrating to LAVA a energy saving or LED RGB lamps. This option surely will leave fascinated a who observes it... a more spectacular and pleasure environment.





CAPSULE COLLECTION BY **KARIM RASHID**

VLEK

VLEK speaks of our roots as a human, our roots on this glorious green earth and our growth towards a new future driven by digital technology.

Besides its attractive & original design, VLEK also interprets the concept "sustainability of our habitat", since with the option of incorporating a self-watering system, permits an autonomy of watering until 120 days, which guarantees the perfect care for your plants even though you are away on vacation, thanks to its water reservoir and feeding system, the plants learn synchronizing watering and saving water the same moment.



OUTDOOR RUGS BY **KARIM RASHID**



TWIST & SHOUT



YOU & ME

GIOVANNONI & GARGAN

"A MATTER OF BALANCE"

STEFANO GIOVANNONI ,ARCHITECT, INDUSTRIAL AND INTERIOR DESIGNER, LIVES AND WORKS IN MILAN. HE WORKS AS INDUSTRIAL DESIGNER DESIGNING MANY ICONIC BEST SELLERS AND COMMERCIALY SUCCESSFUL PRODUCTS. FOR COMPANY LIKE ALESSI, MAGIS, TOTO, SAMSUNG,SODASTREAM , LAUFEN. ELISA GARGAN GIOVANNONI ,INDUSTRIAL AND INTERIOR DESIGNER , IS STEFANO'S PARTNER AND WIFE. ELISA AND STEFANO WORKING TOGETHER FOR MANY FAMOUS COMPANIES INCLUDING VENETA CUCINE ,MALETTI, L'OREAL,TUBES,BERTAZZONI, BISAZZA, ECT..

Who really are you?

_ Two designers, partners in work and life.

What do you think of when you hear the word plastic?

_Plastic is a material we really like, because as the word itself suggests it gives us the opportunity to create shapses and concepts that it is hard to do with other materials.

What is your favourite colour?

_We both love green. Stefano loves acid green, Elisa prefers emerald green.

Which Vondom item from another designer would you put in your home?

_Besides our products that we have in our terrace, we think that there are many other interesting items but we may need more than one house to put them all in.

What do you prefer, classic or science fiction movies?

_ We love old science-fiction movies, such as Blade Runner, Metropolis, Brazil 2001- A Space Odyssey. But also Quentin Tarantino and new Italian film producers, such as Matteo Garrone, Paulo Sorrentino and Paulo Virzi.

Do you have any *fetich* object?

_ We have too many to list them all.

What was the last thing you bought?

_ Stefano always used to buy music, Hi-Fi CDs and vinyls. Recently he bought antiques from Korea and Elisa bought some coloured glass vases from the fifties, designed by Archimede Seguso.

Do you believe in perfection?

_It's an abstract idea, but it's the goal for any product.

Do you have any fixation or quirky habit?

_Stefano is a perfectionist, he has a lot of quirky habits, especially to do with music and his Hi-Fi. Elisa doesn't have many, she likes classic glasses and tablecloths. For both of us our goal is to prepare perfect dishes.

What do you do when you are not designing?

_We love cooking and going fishing.



COLLECTION BY
GIOVANNONI

BLOW

BLOW Collection designed by Stefano Giovannoni comes from the willing to develop a new family of products in tune with the Pillow family but different in typology. Whether the PILLOW cushion is 'L' bent, in its most simplified conceptual essence, BLOW is a product family that offers a related concept starting from the back-shaped PILLOW that folds forward to create the arms. BLOW springs from the idea of the inflated cushion, offering the more traditional type of easy chair and sofa with armrests. Its comfort as well as its material character permit their use in both indoor and outdoor spaces.





COLLECTION BY **GIOVANNONI**

BLOW springs from the idea of the inflated cushion, offering the more traditional type of easy chair and sofa with armrests. Its comfort as well as its material character permit their use in both indoor and outdoor spaces.

90 35 1/2"



80 31 1/2"



76 30"

BLOW Lounge Chair
BLOW Butaca

190 74 3/4"

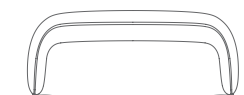

80 31 1/2"

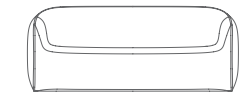

76 30"

BLOW Sofa
BLOW Sofá

120 47 1/4"

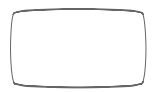

74 29 1/4"



32 12 1/2"

BLOW Coffee Table
BLOW Mesa



BLOW BLOW



New Items Pots

COLLECTION BY
GIOVANNONI&GARGAN

STONES

Stones, is the flowerpot and furniture collection designed by Stefano Giovannoni and Elisa Gargan for VONDOM. As the name suggests, was to develop elements we can find in nature creating a synergy between the natural and the artificial landscape. The material, as well as its original shape permit Stones integrate perfectly into every environment and trans-

mit the elegance. Stones has a great variety of finished, color, and available with lighting by energy saving or RGB LED. As all the products VONDOM, is suitable for outside, even though the most extreme climatic conditions since is manufactured by means of rotational molding made by PE of highest demanding.

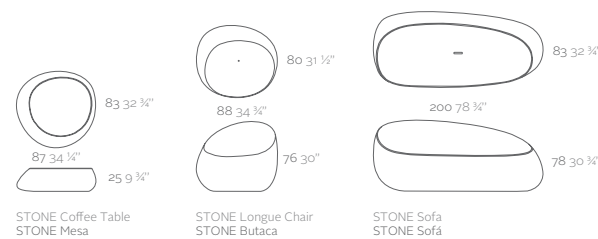





NEW COLORS

2014/15

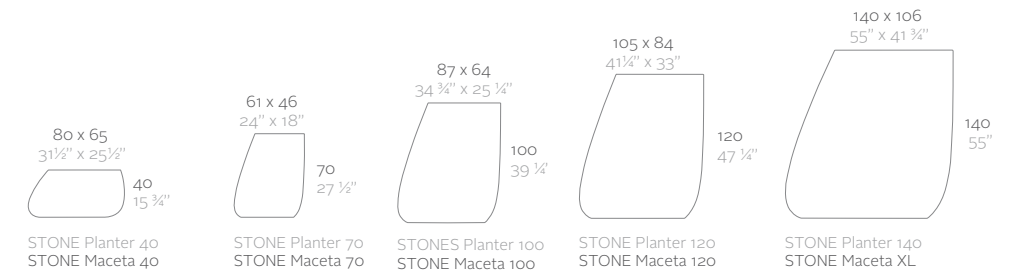

COLLECTION BY STEFANO **GIOVANNONI**

PILLOW

Stefano Giovannoni, one of the most prestigious designers in the world, does an amusing expression to design a genial furniture collection that evokes a chill-out space created by means of cushions. Mediterranean and warm design, universal as all the creations of master Giovannoni that calls to the relax and to enjoy the life.

As all the products VONDOM, is suitable for outside, even for the most extreme climatic conditions since is manufactured by means of rotational molding made by PE of highest request. Exclusive furniture that cause to live and to feel, that facilitate the human contact and the serene conversation.

82 x 94
32 1/4" x 37"



75 29 1/2"

PILLOW Lounge Chair
PILLOW Butaca



67 x 67
26 1/2" x 26 1/2"

20 7 1/4"

PILLOW Coffee Table
PILLOW Mesa



67 x 67
26 1/2" x 26 1/2"

35 13 3/4"

PILLOW Ottoman
PILLOW Puff



67 x 67
26 1/2" x 26 1/2"

35 13 3/4"

PILLOW Planter
PILLOW Maceta



67 26 1/2"

67 x 67
26 1/2" x 26 1/2"

35 13 3/4"

PILLOW Planter
PILLOW Maceta

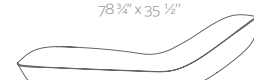

200 x 90
78 3/4" x 35 1/2"

60 23 1/2"

PILLOW Sun Chaise
PILLOW Tumbona



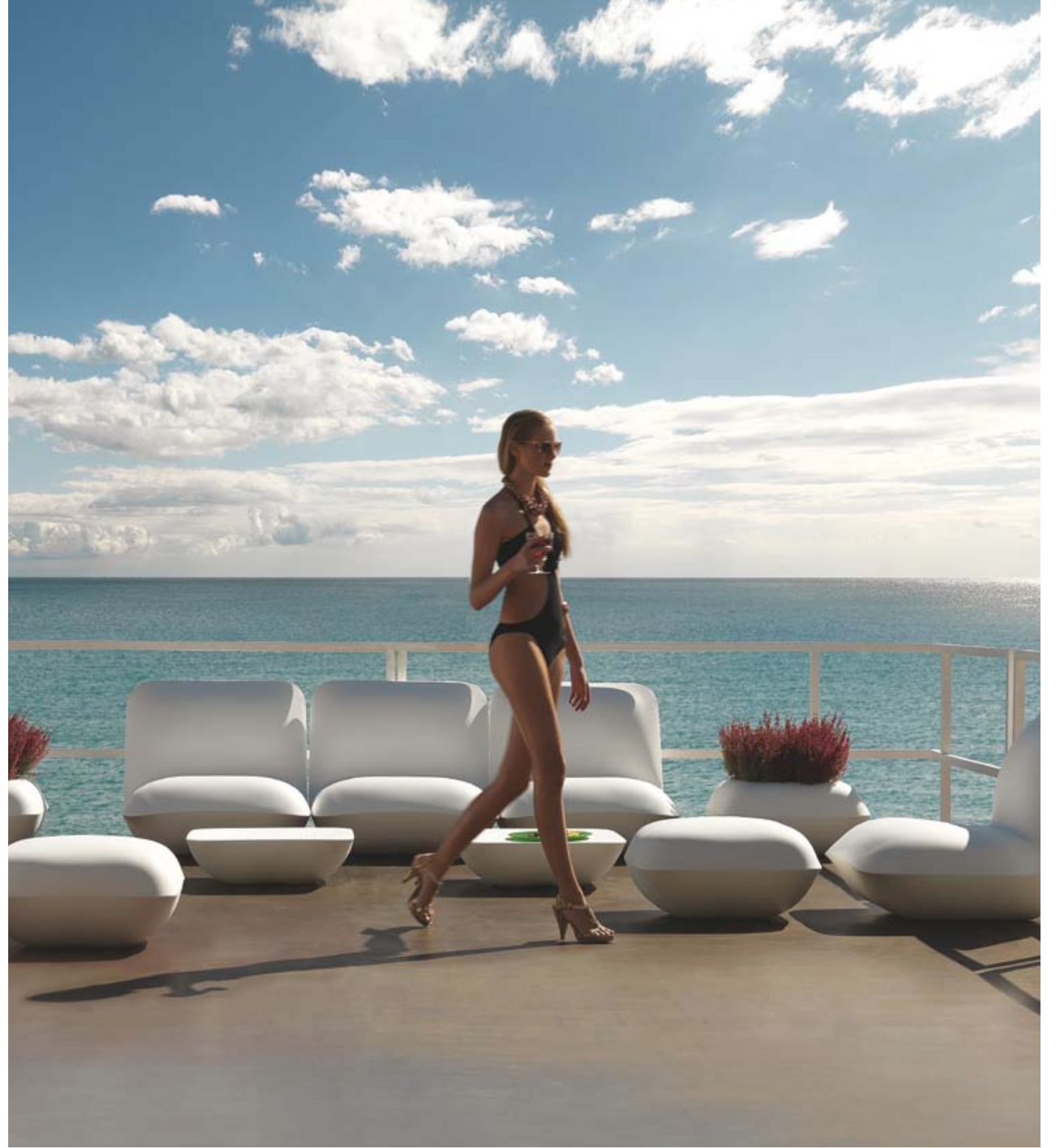
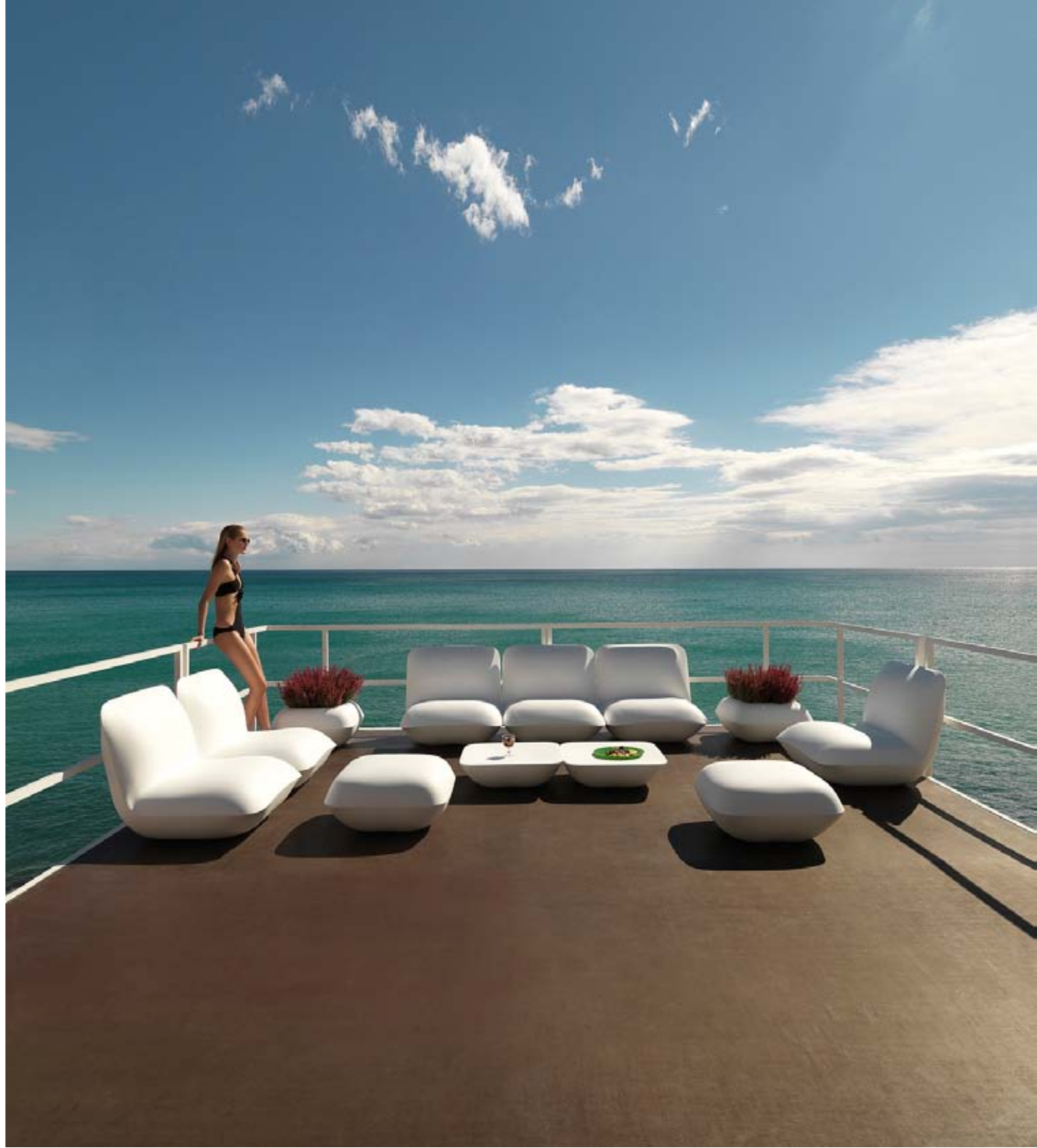

A modern lounge chair and two pillows are positioned on a concrete deck overlooking a swimming pool and the ocean. The scene is bright and serene, with a clear blue sky and calm water. The text is overlaid on the right side of the image.

PILLOW IS
PERFECT FOR YOUR
LEISURE TIME

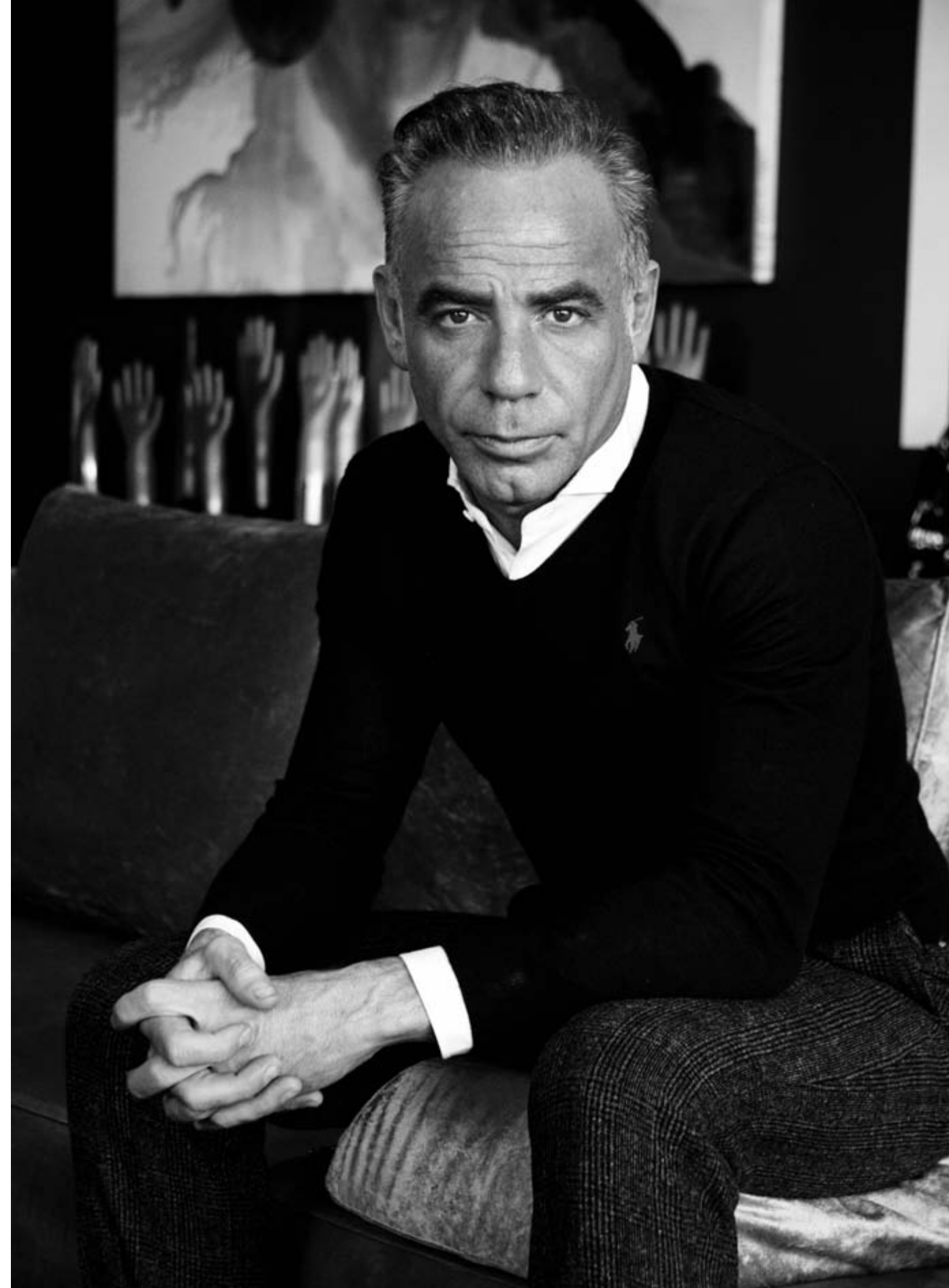

APPROACHING VONDOM
DESIGNERS / A-CERO

A-CERO

"THE BIG SHOW"

JOAQUÍN TORRES (*1969) - RAFAEL LLAMAZARES (*1970), SPAIN. A-CERO JOAQUÍN TORRES ARCHITECTS COMPANY ESTABLISHED IN 1996 WHOSE ACTIVITY FOCUSES ON COMPLETE DEVELOPMENT OF ARCHITECTURAL PROJECTS. THE HUMAN TEAM, LED BY JOAQUÍN TORRES AND HIS PARTNER RAFAEL LLAMAZARES, HAS BEEN GROWING THROUGHOUT THE PAST YEAR AND SUMS UP TO MORE THAN 60 PROFESSIONALS SPREAD OUT THROUGH DIFFERENT OFFICES SPAIN (1), UAE DUBAI (1), DOMINICAN REPUBLIC (1), CURRENTLY WORKING ON PROJECTS OF DIFFERENT MAGNITUDE. "OUR WORKING METHOD IS BASED ON A DETAILED ANALYSIS OF THE CLIENTS NEEDS AND THE PROJECTS PROGRAMME: WE IMAGINE, PROJECT AND PERSUADE. "THE KEY TO OUR SUCCESS IS THAT WE STICK TO THE INITIAL IDEA THROUGHOUT THE WHOLE PROCESS.

Who really are you? A-cero?

R.L. _Rafael Llamazares is a professional person who is dedicated, heart and soul to architecture.

J.T._I'm a man who tries to live quietly and with as much dignity as possible.

What do you think of when you hear the word plastic?

_ For us Plastic means VONDOM

What is your favourite colour?

_White.

Which Vondom item from another designer would you put in your home?

_Apart from our designs for Vondom I find the Ramon Esteve Collection the most interesting.

What do you prefer, classic or science fiction movies?

R.L. _ I prefer science fiction, I really like the movie "Tron", both the original and the Remake.

J.T._If it's a good movie it doesn't matter whether it's science fiction or classic..

Do you have any fetish object?

R.L. _The Barcelona Daybed by Mies.

J.T._The Barcelona Chair by Mies Van Der Rohe.

What was the last thing you bought?

R.L. _ A bicycle I bought in Kapelmur.

J.T._A seventeenth century Indian lattice window

Do you believe in perfection?

_We believe that by being constant in our daily work we can get closer to the path of perfection.

Do you have any fixation or quirky habit?

R.L._I'm a little bit fanatical about organization in work, both mine and that of my team.

J.T._Just one! If only it were just one....

What do you do when you're not designing?

_Oh, lots of things! Studio projects, keeping in touch with family and friends, travel. Well, just living really.

DESIGNS FOR VONDOM:
WING, ALMA, REST, MOONBEAM, OVERLAP

COLLECTION BY **A-CERO**

WING

WING collection by A-cero for VON-DOM, was birth as a result of the folding of the straight and curve lines projection mixed in a dynamic way. The extremes curve and angle are characterized the last stage of the studio A-cero in its architectural level transfer as well to the furniture design, developing commitment for free, delicate and organic line, that generates movement and dissolved sinuously of any symbol of over-orthogonality. Bold pieces that bring the furniture with a huge visual force and offer a notable sculptural and dynamic loading.

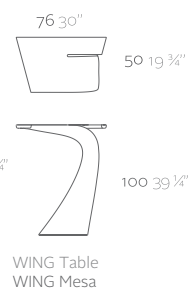
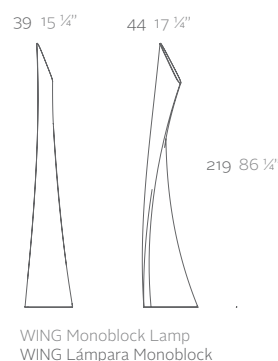



WING A-CERO SCULPTURAL AND DYNAMIC DESIGN

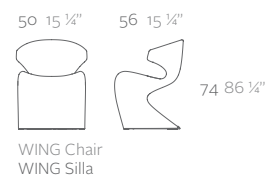

POT COLLECTION BY **A-CERO**

ALMA

An unique collection by its original and innovative design, inspiring in the nature, whose stylist forms recall to the sprig of a plant that from the ascending earth serving as support of the flowers and leaves. With ALMA offers a new concept of the decoration without leaving the practicality out of account, since this flowerpot collection can be installed outdoor maintaining in good condition, even under the most extreme climatic conditions. From the slim forms, along with the dynamic, elegant and lightness features, a collection that integrates in the avant-garde architecture with Characteristic of studio A-cero is born.

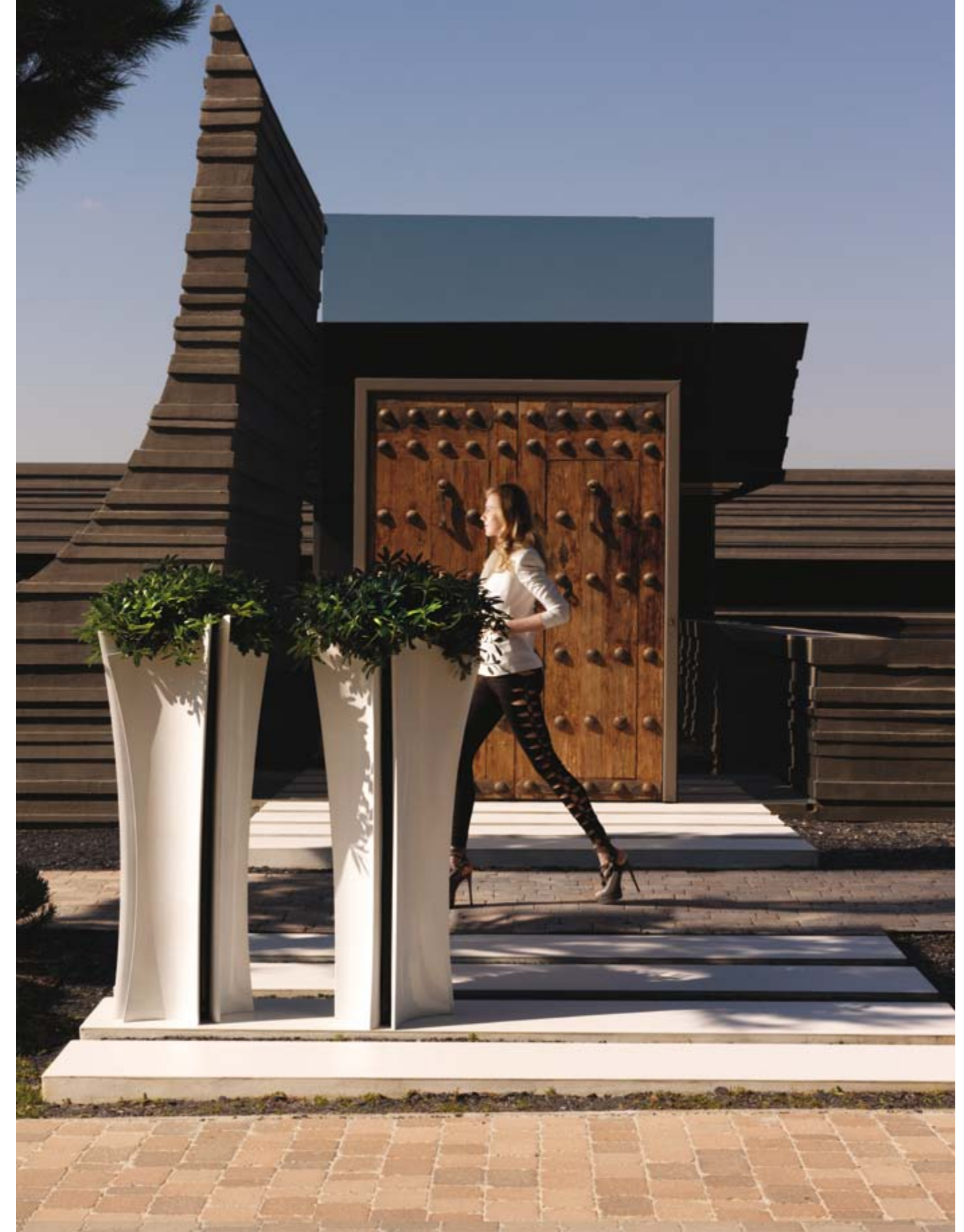
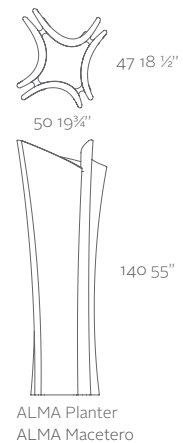

COLLECTION BY **A-CERO**

REST

Simply forms, pure lines and design are the concepts that show the essence from its creators, always loyal to elegance, beauty and exclusivity. A dynamic, light collection full with freshness that offers the maximum comfort to its users integrating in the avant-garde architecture IN&OUT.

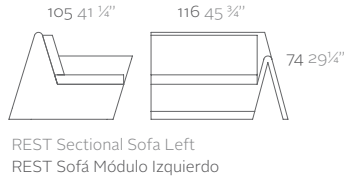
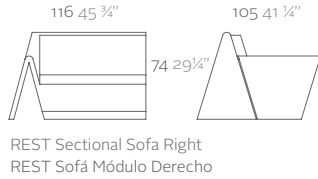
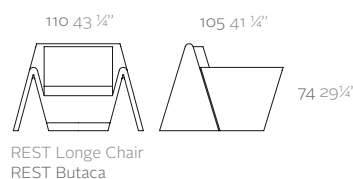



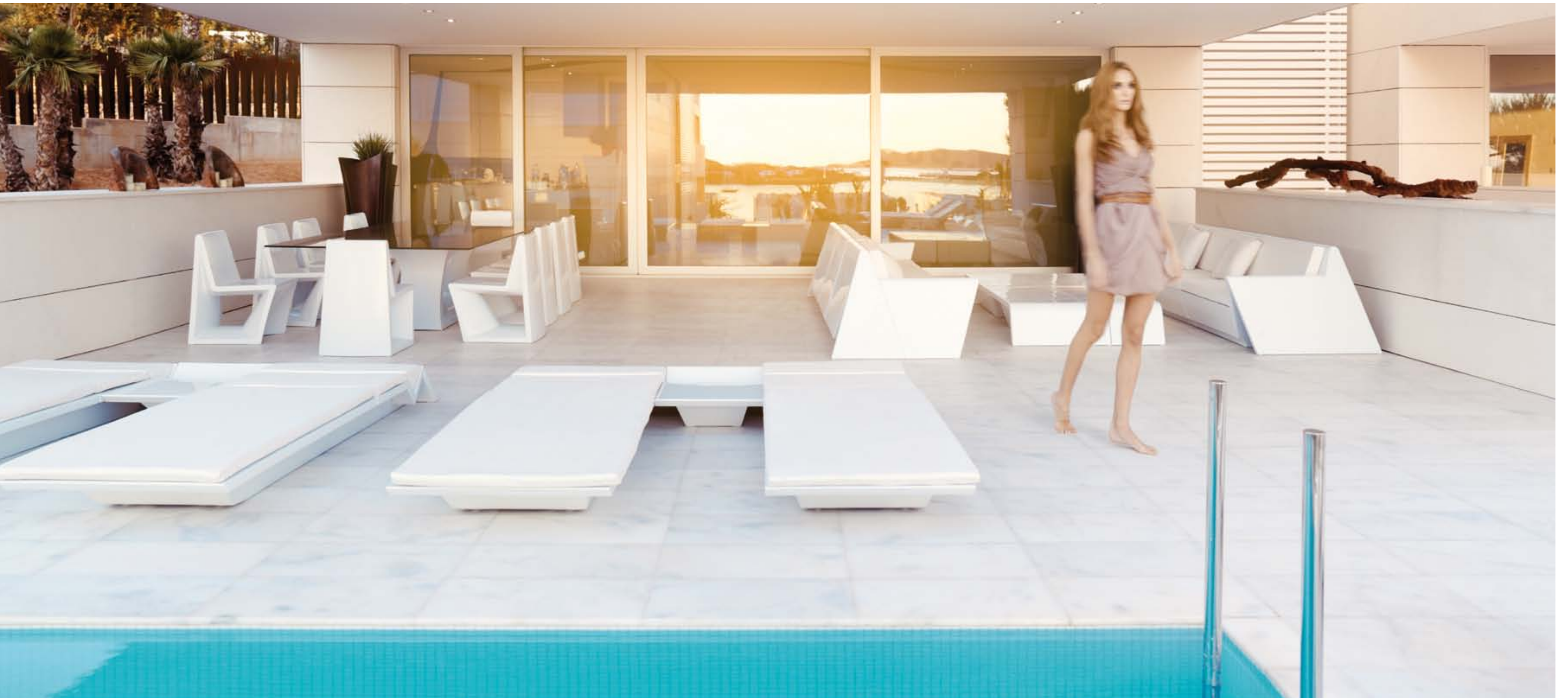

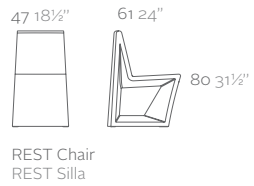

AVANT-GARDE ARCHITECTURE IN&OUT

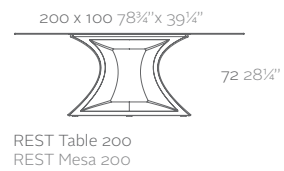
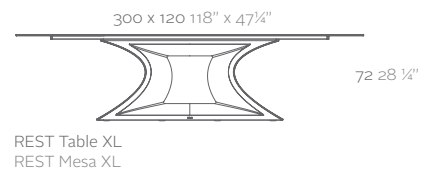
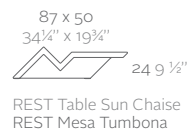
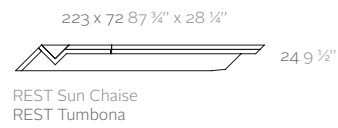

OUTDOOR
RUGS BY **A-CERO**



OVERLAP



MOONBEAM

MARISCAL

La joie de vivre

JAVIER MARISCAL IS, FIRST AND FOREMOST, AN IMAGE CREATOR WHO DEVELOPS HIS WORK USING ALL KINDS OF SUPPORTS AND DISCIPLINES. FURNITURE DESIGN, PAINTING, SCULPTURE, ILLUSTRATIONS, INTERIOR DESIGN, GRAPHIC DESIGN, LANDSCAPING, GARDENING AND SO ON ARE ALL THE OBJECT OF HIS PROFESSIONAL, VITAL ACTIVITY. HE HAS COLLABORATED WITH COMPANIES SUCH AS MEMPHIS, AKABA, BIDASOA, BD EDICIONES DE DISEÑO, MOROSO, NANI MARQUINA, VORWERK, EQUIPAJE, ALESSI, SANGETSU, MAGIS, COSMIC, AMAT3, SANTA&COLE, LALIQUE AND PHAIDON. MARISCAL EXPRESSES HIMSELF USING A PERSONAL LANGUAGE THAT IS COMPLEX IN ITS INTENTION AND SIMPLE IN ITS STATEMENTS, INNOCENT YET PROVOCATIVE, THAT HE USES TO INNOVATE, RISK AND COMMUNICATE. HE ENJOYS PROVOKING THE EYES THAT LOOK AT HIS WORKS AND CREATING COMPLICITY WITH THEM.

Who really are you?

_ I'm curious. I like to watch, observe, learn and draw everything. I draw the light, the sea, friends, bars, streets and objects.

What do you think of when you hear the word plastic?

_ It is a material that allows us to make outdoor furniture and rugs that are resistant to rain, sun, water, and time.

What is your favourite colour?

_ All colours are beautiful but it's also true to say that some colours suit more than others.

Which Vondom item from another designer would you put in your home?

_ I like the items designed by Vondom Studio.

What do you prefer, classic or science fiction movies?

_ Above all a good movie.

Do you have any *fetich* object?

_ I really like Vespas especially when the first Piaggio manufactured in Italy has been a faithful companion that has took me to lots of different places for many years.

What was the last thing you bought?

_ A Korean brushes set.

Do you believe in perfection?

_ I believe in doing things well, seeking good solutions, keeping abreast of new technology and new ideas which will continue to open more and more doors to work and having fun.

Do you have any fixation or quirky habit?

_ I have some habits but I can overcome them easily.

What do you do when you are not designing?

_ Some say that design is a way of life. I also read, travel and go for walks.

DESIGNS FOR VONDOM:

SABINAS, BLANCA, MOMA, MORA, ZEBRA, AZULEJO, FLORES DE KLEE.



COLLECTION BY **JAVIER MARISCAL**

MOMA

It was decided to do a new typology of furniture to unite the function of a flowerpot and an outdoor table, thus MOMA was born, a collection characterizes for its versatility and originality. The first sketches presented organic shapes that in the development of the project they were deriving toward more architectural forms that recall toe column with capital or to corbel.

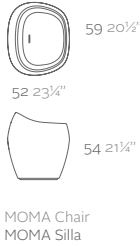
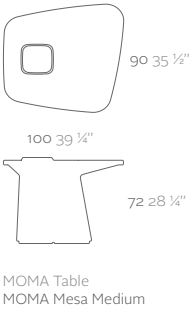

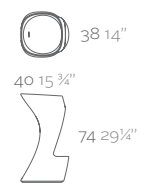

MOMA Bar Stool
MOMA Taburete

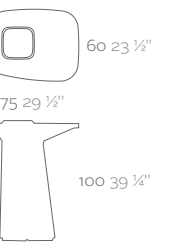

MOMA Bar Table
MOMA Mesa High

MOMA
BY
MARISCAL
ORGANIC
 FRESH

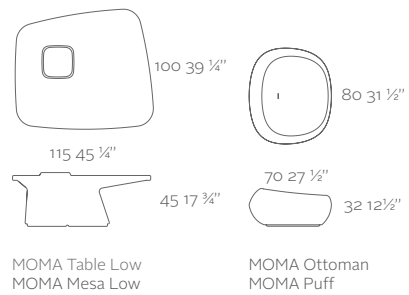

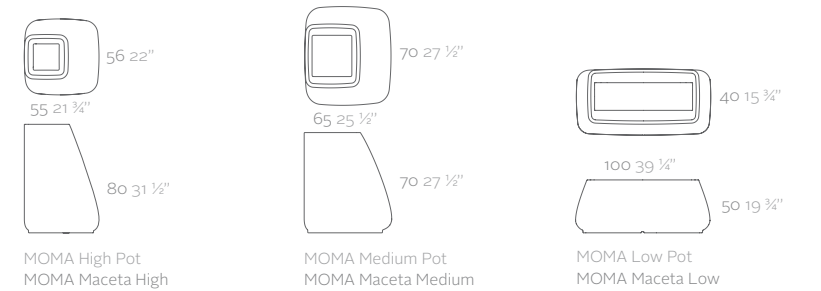
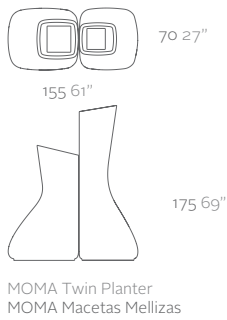

COLLECTION BY **JAVIER MARISCAL**

SABINAS

It's inspired in a fluid organic shape, running away to the straight lines and the geometry. Its outline looks like dunes, a female curves. This collection goes beyond of playing a role, but suggests a special friendship and tenderness relationship with the user. As all collections of the author remits a very mariscaliano formal code.

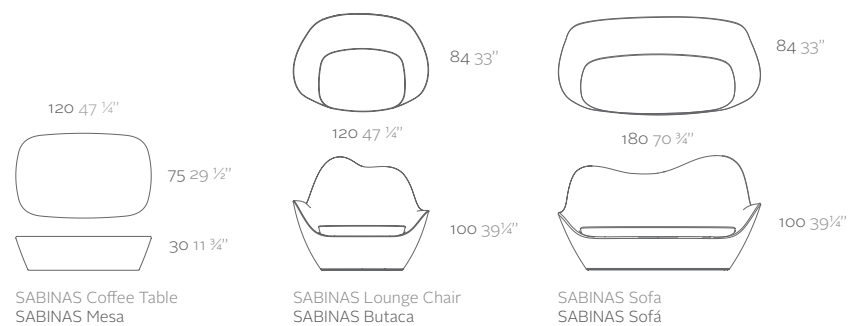





LAMP SET BY **JAVIER MARISCAL**

MORA

The lighting MORA, is inspired in the traditional metallic punching lamps. The design, the functionality and the ecology are the most standing out elements of this collection. The shape has deriving toward a compact volume of pure geometry, meanwhile the texture creates a contrast with lines draws a bas-relief, drawn by Javier Mariscal, considering to offer the consumer a balanced, relaxing light with own personality.

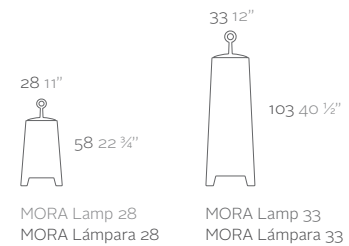

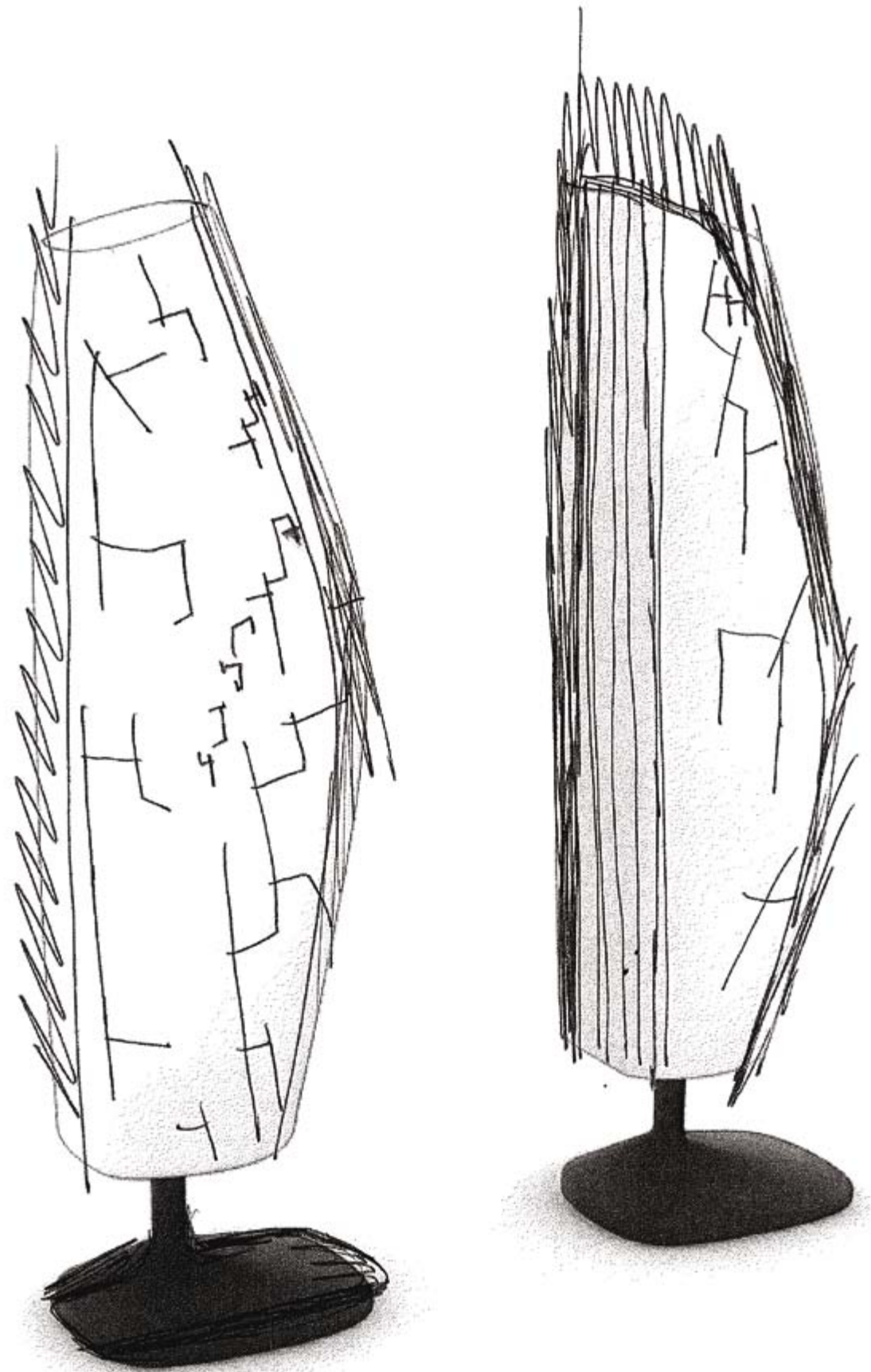

LAMP SET BY **JAVIER MARISCAL**

BLANCA

BLANCA adopts a form in which is recognized by the graphic language of Javier Mariscal. Its silhouette is round, organic, as a ripe fruit or a pregnant woman. BLANCA combines the language of the designer with the technology of VONDOM, giving as a result an expressive piece and of high quality.

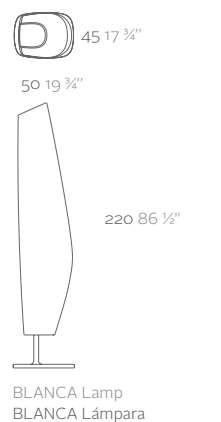

OUTDOOR RUGS
BY **JAVIER MARISCAL**

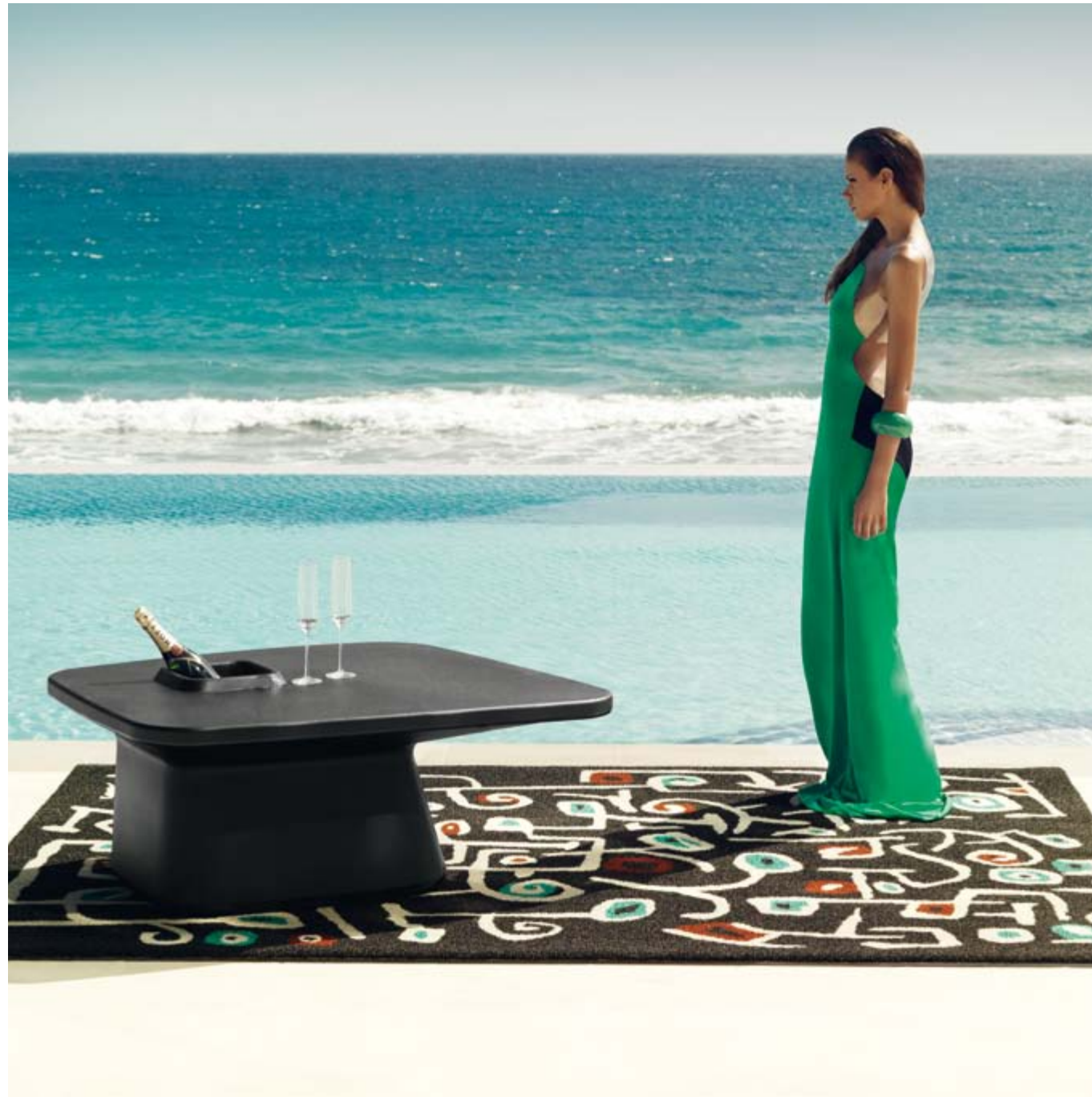

LAS FLORES DE KLEE



AZULEJO



ZEBRA



APPROACHING VONDOM
DESIGNERS / JMFERRERO

JM FERRERO

"THE GENTLEMAN"

ELEGANT, THOUGHTFUL, SOPHISTICATED AND WITH A CERTAIN DOSE OF DANDYISM

ESTUDI{H}AC IS A CREATIVE COMPANY FOUNDED IN 2003 BY JOSE MANUEL FERRERO, WHERE MADE-TO-MEASURE WORKS ARE REALIZED FOR VISIONARY CLIENTS WHO BET FOR NEW CREATIVE SOLUTIONS WITH VALUE OF BRAND, WITHOUT CLOSING THE CHANNEL OF COMMUNICATION BETWEEN THE EQUIPMENT OF DESIGN AND THE COMPANY. IN HER SPECIALIZED EQUIPMENTS OF WORK BELIEVE THEMSELVES WHERE THEY ALL CONTRIBUTE CREATIVE, INNOVATIVE AND DIFFERENT SOLUTIONS TO OBTAIN A PROJECT THAT EXCEEDS THE EXPECTATIONS AND INITIAL RESULTS OF SUCCESS FOR THAT THE CLIENT WAITS. OUR PROJECTS ANSWER TO AN ELEGANCE BESPOKE, ARE RETAILERS AND EXPRESSIVE, COMBINE TEXTURES AND MADE-TO-MEASURE MATERIALS TO WAKE UNEXPECTED EMOTIONS UP. ESTUDI{H}AC AS AN ATELIER OF DESIGN.

Who really are you?

_I'm a Valencian designer who is thoughtful, observant, restless, emotional and an explorer.

What do you think of when you hear the word plastic?

_A large door of opportunity to be creative using new shapes and textures.

Which is your favorite color?

_English Green.

Which Vondom item from another designer would you put in your home?

_Without a doubt various designs of "Rosinantes" by Eero Aarnio, another great iconic design by Eero that means I can chill out and play with Mr. Paul (the baby of the house).

What do you prefer, classic or science fiction movies?

_Either as long as there is a good plot and it helps me to unwind. Sometimes I can be inspired by a new idea at the same time.

Do you have any *fetish* object?

_The letter H, which I have collected over many years and is a collection which is continuing to grow with the help of my friends. Also Oxford shoes and socks with coloured motifs and patterns.

What was the last thing you bought?

_An H to add to my collection which I found this week in a curiosity shop with my friends.

Do you believe in perfection?

_In perfection, no. However I believe in taking care and giving attention to detail. Perfection may come in time as you look again and modify details.

Do you have any fixation or quirky habit?

_I lock the car several times but still check it's locked by trying the door.

What do you do when you are not designing?

_Enjoy Mr. Paul and my family.

DESIGNS FOR VONDOM
VASES & MARQUIS

COLLECTION BY **JMFERRERO_ESTUDIO{H}AC**

VASES

Flowerpots, furniture and lighting which forms are inspired in the sculpture of the diamonds, obtaining some pieces of clear shapes and of great style. A collection designed to offer the consumers a modern and stylish decoration during the day, and an unique ambient during the night, creating a great visual impact that will surely draw the attention.

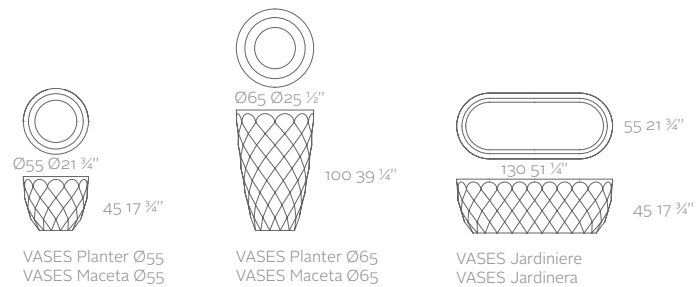



VASES Stackable Chair
VASES Silla apilable

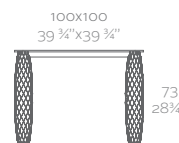

VASES Table 100x100
VASES Mesa 100x100

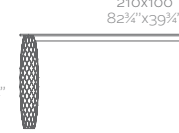

VASES Table 210x100
VASES Mesa 210x100

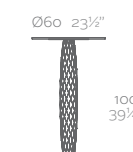

VASES Bar Table
VASES Mesa Alta

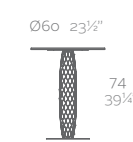

VASES Table
VASES Mesa

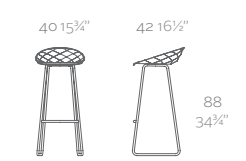

VASES Bar Stool
VASES Taburete



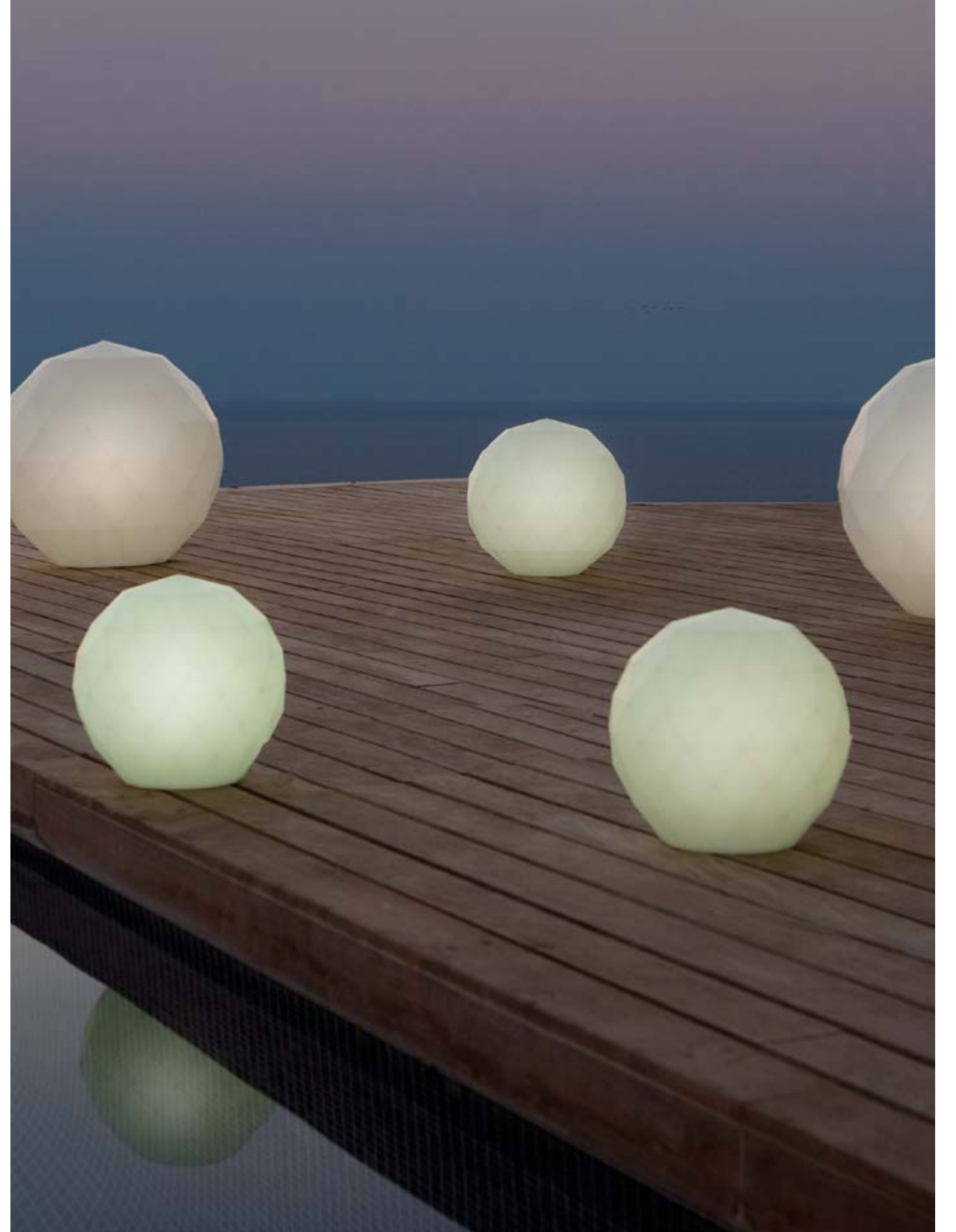

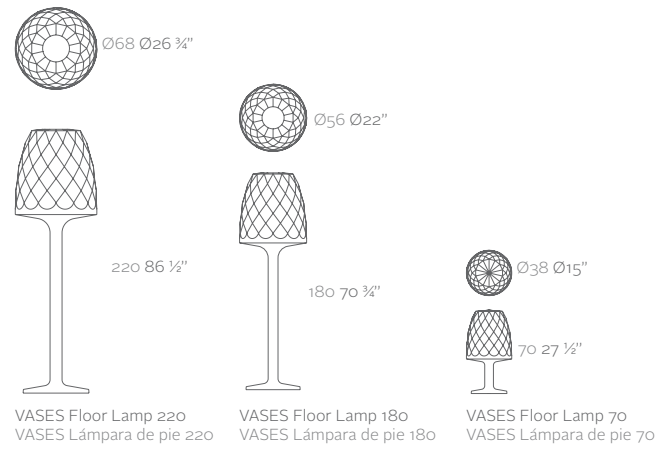

LA ISLA BONITA VASES

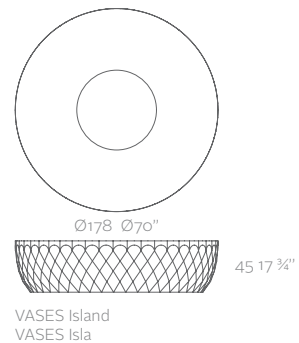

COLLECTION BY JMFERRERO_ESTUDIOK}AC

MAR- QUIS

Marquis born from the inspiration of diamond cutting. Its polygonal design refers to facets created through its cutting. The clear and stylish shapes get a great visual impact. Circular or oval, on 5 combinations of bold colours offer great dynamism to the space. Its soft texture achieved through polyethylene fibers allows outdoor use, being resistant to UV rays.



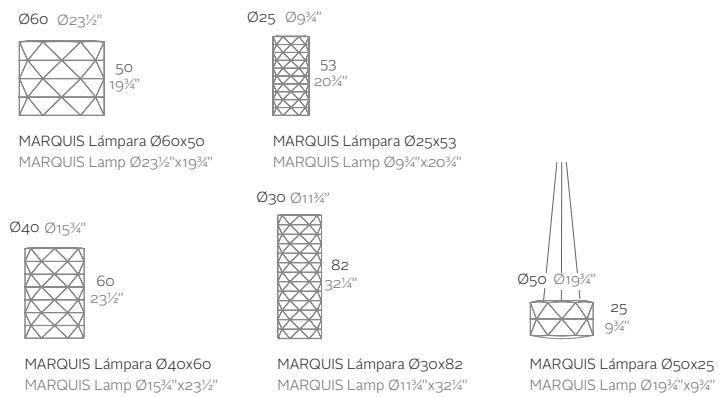
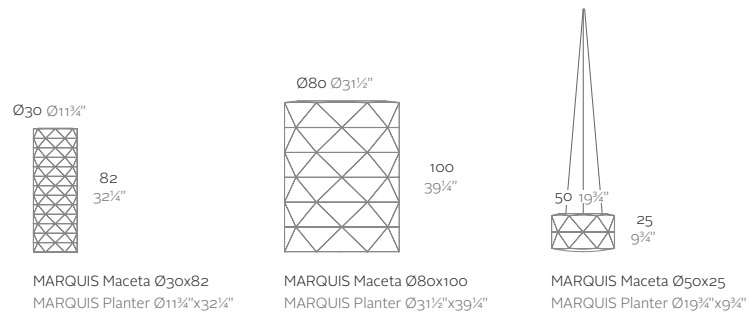
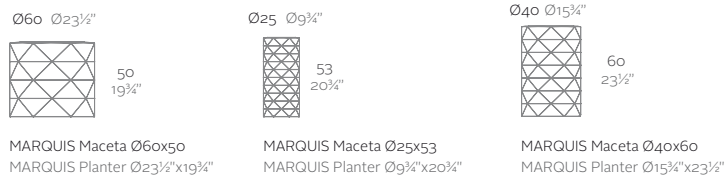

TERESA SAPEY

L'italiana in Madrid

STUDIO TERESA SAPEY IS AN ARCHITECTURE AND DESIGN STUDIO BASED IN MADRID SINCE IT WAS FOUNDED IN 1990. THE TEAM'S GUIDING FORCE STREAMS FROM CURIOSITY AND ENERGY. IN FACT, THE RANGE OF FIELDS APPROACHED BY THIS PRACTICE IS EXTREMELY BROAD: IT VARIES FROM SPACES TO DISPLAYS VIA FURNITURE, GRAPHICS AND EDITORIAL WORKS. PROJECTS NOT ONLY STEM FROM FEELINGS, BUT THEY ARE ALSO CAPABLE OF TRANSMITTING THESE SAME EMOTIONS TO THEIR CLIENTS AND COSTUMERS. "BY WORKING WITH SPACES MY AIM IS TO BE TOUCHING AND THEREFORE RENDER EMOTIONS PALPABLE: THREE-DIMENSIONAL, EVEN FOUR-DIMENSIONAL. NO MATTER WHAT THE FEELING IS, AS FAR AS IT IS A FEELING, I WOULD GO FOR IT! I BELIEVE THAT ARCHITECTURE SHOULD INTERPRET, BUILD AND TRANSMIT THESE INSPIRINGLY AND USEFULLY."

who is actually Teresa Sapey?

_That friend of yours whom is also a Designer

What do you think of when you hear the word plastic?

_Contemporary World

What is your favorite color?

_White, but also orange.

Which Vondom item from another designer would you put in your home?

_I think you should ask which one I would'nt use at home. I like all of them: Javier Mariscal, Stefano Giovannoni and Elisa Gargan, A-cero, Ora Íto, Ramon Esteve, Jose Manuel Ferrero, Eero Aarnio, Harry&Camila, Karim Rashid, Fabio Novembre, Archirivolto, Lucovica+Roberto Palomba, Ross Lovegrove and the VONDOM Studio.

What do you prefer, classic or science fiction movies?

_Voyage dans la Lune, by Georges Méliès. Both of them.

Do you have any *fetish* object?

_My glasses.

What was the last thing you bought?

_A pair of shoes with flower patterns.

Do you believe in perfection?

_I believe in the Perfection Quest. I think it is possible to look for it. However, we must acknowledge that we are not perfect people just because we believe to be so.

Do you have any fixation or quirky habit?

_Yes, taking my shoes off, the delicious jamon ibérico (spanish premium ham) and, of course, champagne.

What do you do when you are not designing?

_I'm thinking about the design projects I should finish later on.

DESIGNS FOR VONDOM:
ADAN, CHEMISTUBES, CHRISMY, PIANOPIANO, KOI



COLLECTION BY **TERESA SAPEY**

ADAN

ADAN, as a diamond with cutting. He is the result of the balance between the past and the future. More than objects, they are multifunctional architecture pieces, since besides vases can be used as seats, flower planters, auxiliary tables... They are lifestyle objects that mark the tendency integrating perfectly in all kinds of styles and their materials permit their extensive use in both outdoor and indoor.

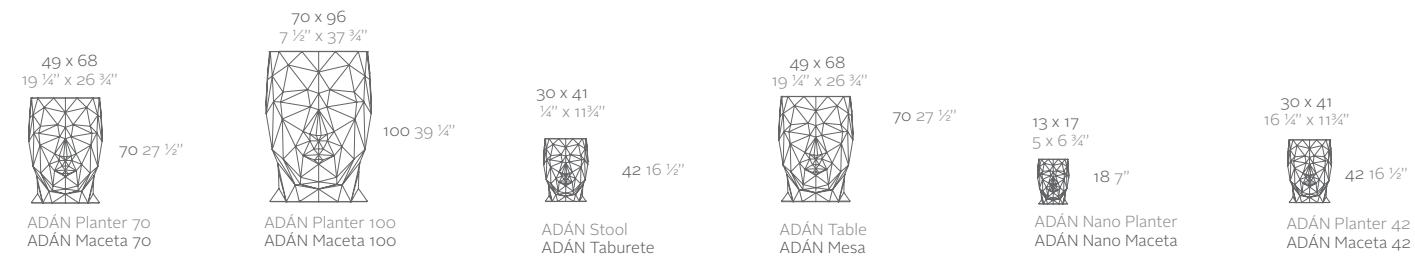





CAPSULE COLLECTION BY **TERESA SAPEY**

CHEMIS

CHEMISTUBES, is based on the decontextualization, through the increasing of size (intervention in scale), the use of different materials to the original one (in this case, the ecological material of resin of polyethylene by the technique of rotational moulding), and the change of using for which the object was in the mind at first, gives shape to a new object now. What

a laboratory container was before is now a decorative element IN&OUT. Besides offering the finished in a great variety of matt or lacquered colours, also offers you the value added lighting, in which gives the collection a more interesting touch, creating a surprising, harmonic environment and with great elegance for any interior & exterior space.



FLASK

A x B
 Ø36 x 65 Ø14 1/4" x 25 1/2"
 Ø55 x 100 Ø21 3/4" x 39 1/4"



ERLENMEYER

A x B
 Ø36 x 65 Ø14 1/4" x 25 1/2"
 Ø55 x 100 Ø21 3/4" x 39 1/4"

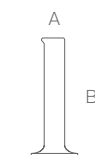

PIPE

A x B
 Ø30 x 65 Ø11 3/4" x 25 1/2"
 Ø40 x 100 Ø15 3/4" x 39 1/4"

BY TERESA SAPEY

CHRISMY

Inspired in natural, organic and elegant shapes that rise towards its peak in each of its silhouette to-and-fro movement. Its interior lighting creates a true enveloping atmospheres to be able to enjoy them in different spaces. A renewed classic, refined in its timeless modernity, easily adaptable. Pure visual magic achieved through its logical continuation.

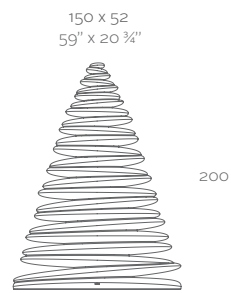

CHRISMY Tree 200 cm/78 3/4"
CHRISMY Árbol 200 cm/78 3/4"



CHRISMY Tree 150 cm/59"
CHRISMY Árbol 150 cm/59"

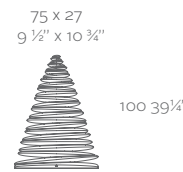

CHRISMY Tree 100 cm/59"
CHRISMY Árbol 100 cm/59"

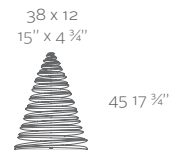

CHRISMY Tree 45 cm/17 3/4"
CHRISMY Árbol 45 cm/17 3/4"



CHRISMY Nano Tree 25 cm/9 3/4"
CHRISMY Nano Árbol 25 cm/9 3/4"



OUTDOOR RUGS BY **TERESA SAPEY**



PIANO PIANO



KOI



PALOMBA'S

"THE MAGIC TANDEM"

LUDOVICA+ROBERTO PALOMBA'S WORK HAS ALWAYS BEEN RICH OF CULTURAL REFERENCES. THEIR PROJECTS ARE DERIVED FROM OBSERVATIONS OF CHANGE IN HUMAN BEHAVIOR. THEIR MISSION IS TO GENERATE PRODUCTS THAT MERGE FUNCTION, INNOVATION AND LONGEVITY - INTIMATE AND EMOTIONAL CONNECTIONS THAT LAST. "WE BELIEVE THAT GOOD DESIGN ALREADY EXIST IN A SORT OF COLLECTIVE UNCONSCIOUSNESS AND OUR TASK IS TO MOLD AND DELIVER THEM. A TRULY SUCCESSFUL PIECE OF DESIGN MUST FEEL FRESH BUT NOT UNFAMILIAR WHEN IT IS DISCOVERED."

Who are really Ludovica + Roberto Palomba??

_A man and a woman who love their life and their job

What do you think of when you hear the word plastic?

_It remind us the rainbow, that has lots of colors that together become white.

What is your favourite colour?

_Ludovica: white
_Roberto: Black

Which Vondom item from another designer would you put in your home?

_Ludovica: Blanca Lamps by Javier Mariscal
_Roberto: Pillow by Stefano Giovannoni

What do you prefer, classic or science fiction movies?_Lu-
dovica: all the movies, except the one very violent and ag-
gressive _Roberto: vintage

Do you have any *fetish* object?

_Ludovica: my Hermes bags _Roberto: my iphone

What was the last thing you bought?

_Ludovica: a new mobile for Roberto.
_Roberto: a Hermes bag for Ludovica.

Do you believe in perfection?

_We think that perfection is boring, we believe in imperfec-
tion. In this way you can go ahead and learn always new things.

Do you have any fixation or quirky habit?

_Roberto: Not really, I change very often. But I have a collec-
tion of elephants.
_Ludovica: I love theater and in the morning I like to find the
table already set for breakfast.

What do you do when you are not designing?

_Reading, travelling, dancing, loving, watching movies, visiting
exhibitions...

COLLECTION BY **LUDOVICA+ROBERTO PALOMBA**

BONES

Bones is elegant by its slimness but at the same time strong by its conception. Its generous volume is alleviated for a subtle edge that makes it light. Bones is reversible, it is to say can be planted with the wide part or to use that part as base whenever the greater stability to be needed or by esthetics. By the level of engineering Bones is fantastic, an invisible internal structure provides the necessary strength transmitting the weight from the base of the container to the base of the flowerpot for achieve to support the weight of any plant or tree.

Bones is manufactured in resin of PE by means of the rotational molding technique and is available with multiples finished made in VONDOM.



HARRY & CAMILA

FUTURISTIC HANDICRAFTS

KNOWN FOR THEIR MYSTERIOUS OBJECTS, EXEMPLARS OF VIBRANT DESIGN OF THE 21ST CENTURY. THE FUTURISTIC SHAPES ARE REMINISCENT OF TECHNOLOGIES APPLIED TO HIGH SPEED, THE IMAGINARY OF HARRY&CAMILA DRAWING ON AERONAUTICAL PERFORMANCES, WITH FANTASIES OF AIRCRAFT WINGS, SPACE TRAVEL THEIR RESULTING DESIGN APPROACH CONCENTRATES ON EXPERIMENTATION WITH MATERIALS AND TOPOLOGIES. HARRY IS FROM THE NETHERLANDS, CLASS 1966, INDUSTRIAL DESIGNER WITH A DEGREE FROM THE DESIGN ACADEMY. IN 2002 HARRY&CAMILA MOVED TO BARCELONA BUT CONTINUE TO SPEND TIME IN THEIR ADOPTED HOME WORKING WITH A NUMBER OF DESIGN MANUFACTURES. A GOOD MIX BETWEEN THE DUTCH FREE SPIRIT AND LATIN THEY WORK ACROSS A WIDE RANGE OF DISCIPLINES SIGNING FOR CLIENTS WORLDWIDE A.O ALESSI, DEDON, FONTANA JLINDEBERG+PUMA, LIVING DIVANI, ROSENTHAL STUDIO-LINE.

Who really are you?

_Harry: I was born in Breda in the Netherlands in 1966. I graduated as an industrial designer from the Design Academy in Eindhoven.

_Camilla: I'm of Chilean nationality, born in Cuba in 1971 and I grew up in Mexico. I graduated with a degree in fashion design from the Instituto Marangoni in Milan.

_We met each other while we were studying for our master's in The Domus Academy in Milan in 1994

What do you think of when you hear the word plastic?

_ Everything is possible....stretchy...flowing....elastic....transforming.

What is your favourite colour?

_Yves Klein Blue

Which Vondom item from another designer would you put in your home?

_Ora ito's stuff

What do you prefer, classic or science fiction movies?

_A Space Odyssey.

Do you have any fetish object?

_Mexican dolls.

What was the last thing you bought?

_A ski jacket from Columbia.

Do you believe in perfection?

_It should be there or within our reach.....that is our goal.....and I hope that sometimes we will reach it.....but until then we will always see something that can be improved.....probably it will always be like that as things are time related.

Do you have any fixation or quirky habit?

_We're control freaks.

What do you do when you are not designing?

_ Right now ski-ing.... Yeeeeeah!





POT SET BY **HARRY&CAMILA**

BYE-BYE

The artistic couple's intention for this new collection: Two completely different shapes - an abstract greeting figure at the upper edge and sole geometric at the lower edge- appear side-by-side but never seem to touch each other, thus creating additional interest. A vertical running line turns the object into an entity in its own right, as if by magic. Its perspective extruded cartoon like space appearance symbolizes travelling at the speed of light. The fascination of Bye-Bye is harboured in this contrast between simultaneous unity and inner conflict.

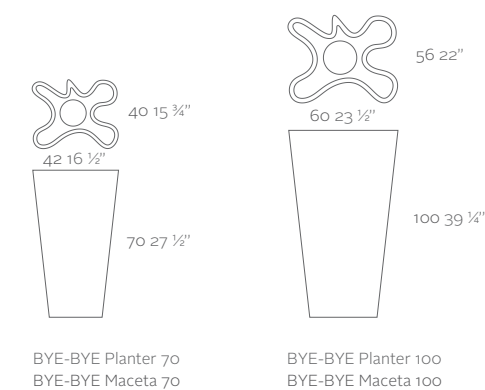

AGATHA

"THE QUEEN OF HEARTS"

AGATHA RUIZ DE LA PRADA FIRST STEPPED INTO THE FASHION WORLD IN 1981. THE COLLECTION PROVED TO BE SUCH A SUCCESS THAT SHE SOON OPENED HER FIRST STUDIO-SHOP IN THE SPANISH CAPITAL AND STARTED TO PARTICIPATE IN FASHION SHOWS IN MADRID AND BARCELONA. ALTHOUGH AGATHA GAINED A CERTAIN LEVEL OF RECOGNITION EARLY ON IN HER CAREER, HER TRUE FASHION BREAKTHROUGH CAME WHEN SHE ALLIED FORCES WITH ONE OF SPAIN'S MOST IMPORTANT DEPARTMENT STORES, EL CORTE INGLÉS. THANKS TO THIS PARTNERSHIP, THE DESIGNER'S COLLECTIONS WERE SOON DISTRIBUTED THROUGHOUT THE ENTIRE NATIONAL TERRITORY. HAVING CONQUERED SPAIN, AGATHA LITTLE BY LITTLE STARTED TO CROSS BORDERS AND GAIN INTERNATIONAL RECOGNITION BY MEANS OF HER FASHION SHOWS AND EXHIBITIONS AND THEN EXPANDED THE FAMILY OF PRODUCTS: CLOTHES, FURNITURE, PERFUMES...

Who really are you?

_I'm a designer who's crazy about contemporary art, very concerned about ecology but most of all someone who tries to be consistent in my life.

What do you think of when you hear the word plastic?

_Recycling.

Which is your favorite color?

_Fuchsia.

Which Vondom item from another designer would you put in your home?

_Any of Karim Rashid's designs. He's a friend of mine and he has also promoted my New York shop.

What would you prefer, Classic or Science Fiction movie?

_I love classic movies. But my favourite is "Cabaret", set in the 30's.

Do you have any *fetish* object?

_I love tights and tiaras.

What was the last thing you bought?

_Cotton tights from El Corte Ingles.

Do you believe in perfection?

_I believe in the pursuit of perfection.

Do you have any fixation or quirky habit?

_I'm obsessed with cleaning.

What do you do when you are not designing?

_ I like reading and walking my dogs.



COLLECTION BY
AGATHA RUIZ DE LA PRADA

AGATHA

The freshness, innocence and spontaneity reaches VONDOM by the hand of the collection AGATHA by AGATHA RUIZ DE LA PRADA, the first Kids collection of VONDOM. The characteristic icons of the designer, perceived instantly by their simple, sweet and refined shapes. A funny, creative and optimistic composition integrated throughout infantile codes: flowers, hearts... This Kids furniture collection consists of three basic elements,

pot, mini table and chair. A flower with large petals is the result of this table and pot which are accompanied by heart-shaped stools. Its highly resistant material allows its usage in exterior space, for be able to enjoy as outdoor playing area. A dream garden where catching the vitality, imagination and ingenuity of the kids thanks to these flashy design pieces.

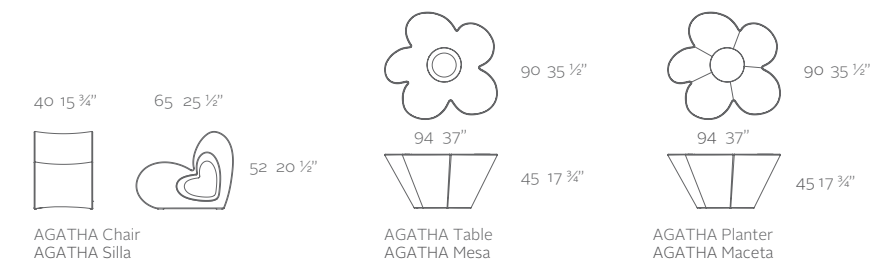



GABRIELE BURATTI, ARCHITECT AND PROFESSOR FOR INTERIOR DESIGN AT THE FACOLTÀ DEL DESIGN OF THE POLITECNICO DI MILANO (2003-2010) AND OSCAR BURATTI, ARCHITECT, SET UP THE AGENCY BURATTI+BATTISTON ARCHITECTS. THE OFFICE CARRIES OUT RESIDENTIAL, COMMERCIAL AND INDUSTRIAL BUILDINGS; THEY DESIGN WORKING, EXHIBIT AND RETAIL SPACES FOR AUTOMOBILI LAMBORGHINI, LA PERLA, HUSQVARNA MOTORCYCLES, OROBLÙ, BMW. IN THE PRODUCT DESIGN FIELD THEY DESIGN FOR ANTONIO LUPI, B&B ITALIA, IGUZZINI, POLIFORM, POLTRONA FRAU, ROCA, TECNO.

APPROACHING VONDOM
DESIGNERS / GABRIELE+OSCAR BURATTI

BURATTI

Oscar And Gabriele

Who really are you?

_We are brothers, architects and designers. Following the best Italian tradition from the very start of our business, we have chosen to work with different levels of architectural projects from furniture design to interior design, from single buildings to whole urban communities. We use constant research to give quality and control to each project.

What do you think of when you hear the word plastic?

_ Without a doubt technology and new research. In contrast to other materials, like wood and stone that have a mass and are worked with cuts, finishes and assembly parts of the same material, plastic does not have an original form. We are very interested in developing the concept of creating the material as part of the process, going straight from the powder to a molded, finished project without intermediate stages.

Which is your favorite color?

_In all our architectural projects colour is a very important material. We like it when it is part of the material and not merely used as a surface finishing. If we exclude white and black, which are always present in our projects, then we don't have any colour preference. We are always looking for new, original tones that we often combine together. There was a time for red, now it's yellow, the next upcoming colour will be pink.

Which Vondom item from another designer would you put in your home?

_It's easy to use plastic to form shapes that become outdated. Instead we are interested in an elegance that will distinguish each project. The item we like the most among those in the Vondom collection is the "Roulette" armchair by Eero Aamio, a timeless item designed by a great master designer.

What would you prefer, Classic or Science Fiction movie?

_Every moment represents a mixture of past experiences and traditions and the numerous tensions and technologies of the future. Since we are both fathers with very small children, at this point in our life we prefer cartoons which are technologically advanced and transmit an important social content.

Do you have any fetish object?

G_ At home hanging on my wall like an object of art I have an unrefined structure of Gio Ponti's "Superlegger's chair" from the 50's.
O_ Yes motorbikes. I love motorbikes because they represent the fine balance between shape and function.

What was the last thing you bought?

_A book about Dino Gavina.

Do you believe in perfection?

_Each of our projects represents a search for perfection. Perfection of ideas and attention to details is the function of harmony between the form and the design. Nature represents perfection and every human interference and design must look to the perfection in nature.

Do you have any fixation or quirky habit?

_In our work we redo everything countless times until we believe we have achieved a perfect result.

What do you do when you are not designing?

G_ I like contemporary art and visiting galleries, exhibitions and museums.
O_ I like to mingle with ordinary people in the street and listen to the energy that surrounds them without a definite idea in my mind. Sometimes this inspires my work.

DESIGNS FOR VONDOM: KES

COLLECTION BY **GABRIELE + OSCAR BURATTI**

KES

KES is a modular system seating for furnishing outdoor spaces. The main objective is to create endless and articulated compositions; sofas, chaise and lineal and angular poufs. Armchairs formed by individual elements or large islands as a result of the union of several parts.

The most interesting themes of the project are the structure's flexibility and especially the possibility to move, at all times, the supplementary elements attached to the bases, so that anyone can find his optimal position and his own comfort.



New Collection

EUGENI QUITLLET

"PAGÉS 2.0"

THE CATALAN DESIGNER EUGENI QUITLLET WAS BORN ON 17TH APRIL 1972 IN IBIZA. HE GRADUATED FROM 'LA LLOTJA' ART SCHOOL IN BARCELONA. THROUGH HIS CREATIVE VOCABULARY HE EXCEEDS SIMPLE RELATIONSHIPS BETWEEN FUNCTION AND STYLE UNVEILING INNOVATIVE OBJECTS. BETWEEN DRAWING, SCULPTURE AND CONTEMPORARY ARCHAEOLOGY, QUITLLET LITERALLY REVEALS SILHOUETTES HIDDEN IN THE MATERIAL, EXTREMELY VISUAL SKELETAL OBJECTS ELEGANTLY MASTER FULLNESS AND EMPTINESS OFTEN WITH A TOUCH OF HUMOUR: THE MASTERS CHAIR COMBINES THE 3 CONTOURS OF LEGENDARY SEATS BY EAMES, SAARINEEN AND JACOBSEN, THE K RAY LAMP IS AN ORGANIC UFO, A NETWORK OF VEINS HOLLOWED OUT OF THE MATERIAL WHICH RESULTS IN AN OBJECT SUSPENDED IN A FRAME, HIS SIGNATURE METHOD PREVALENT NATURALLY IN SEVERAL OF THE DESIGNER'S PROJECTS: THE SHINE VASES, THE LIGHT AIR LAMP, THE O'CLOCK LAMP, WITHOUT FORGETTING THE O RING WATCH, A HOLE IN TIME IN THE TRUE SENSE, BEST SELLER OF THE BRAND FOSSIL MODERNISING WATCHMAKING CODES. EUGENI QUITLLET IS A DESIGN WORLD FREAK CAPABLE OF DEVOURING THE WHOLE OF OUR ENVIRONMENT IN HIS OWN WAY TO SERVE IT UP TO US TRANSFORMED.

Who really are you?

_I'm a person who fishes for ideas. I was born in Ibiza and I'm an industrial designer.

What do you think of when you hear the word plastic?

_ Innovation, the basis of my ideas.

What is your favorite color?

_The color of the sea and the land

Which Vondom item from another designer would you put in your home?

_ "Rosinante" by Eero Aarnio.

What would you prefer, Classic or Science Fiction movie?

_A mixture between "Blade Runner" and "The Children of Paradise" by Marcel Came.

Do you have any *fetish* object?

_The chair, an object used to talk, to work...to dream....

What was the last thing you bought?

_A ticket to space.....Some crayons and a notebook.

Do you believe in perfection?

_ I prefer "better" to "perfect". You can do better than perfect.

Do you have any fixation or quirky habit?

_Designing.

What do you do when you are not designing?

_ Carry on designing.



COLLECTION BY
EUGENI QUITLLET

BUM BUM

BUM BUM was born from the principle of not designing objects, but rather musical instruments to be used for another purpose; the same as a person who holds a shell to their ear to hear the ocean. This collection that has tubular shapes allows us to experiment with light and sound simultaneously. It's "argonautic" form enables us to create a new environment, as well as atmospheric spaces, wherever we are.

The collection is made of a sofa, a table, an armchair and a stool, all designed with a great sense of rhythm and balance. It is a collection designed for the sea, Neptune and the mermaids. It's time with the waves...It's that summer dream.



New Collection

JORGE PENSI

The Dreamer

BORN IN BUENOS AIRES IN 1946, HE STUDIED ARCHITECTURE IN HIS HOME CITY. HE LEFT ARGENTINA IN 1975, DREAMING OF NEW HORIZONS AND CHALLENGES. AFTER CROSSING THE OCEAN, HE SETTLED IN BARCELONA AND BECAME A SPANISH CITIZEN. IN 1977, HE WENT INTO PARTNERSHIP WITH ALBERTO LIEVORE. THEY WORKED TOGETHER UNTIL 1984. HE THEN SET UP HIS OWN STUDIO IN BARCELONA'S GOTHIC QUARTER. PENSI BELIEVES THAT PART OF HIS PROFESSIONAL SUCCESS IS DUE TO THE INTIMATE, CLOSE AND WARM RELATIONSHIP HE HAS WITH HIS TEAM AND HIS CLIENTS, ALLOWING SHARED PROJECT DEVELOPMENT WITH OPTIMUM RESULTS. JORGE PENSI HAS GIVEN CONFERENCES, SEMINARS AND WORKSHOPS ALL OVER THE WORLD. JORGE PENSI HAS BEEN AWARDED NUMEROUS PRIZES AND HAS RECEIVED WIDESPREAD RECOGNITION THROUGHOUT HIS CAREER, INCLUDING THE SPANISH NATIONAL DESIGN PRIZE IN 1997, AWARDED BY THE MINISTRY OF INDUSTRY AND ENERGY FOR OUTSTANDING PROFESSIONAL ACHIEVEMENT. HE HAS RECENTLY BECOME KNOWN FOR HIS OTHER PASSION, MUSIC, WHICH HE HAD KEPT TO HIMSELF UNTIL RECENTLY. HE HAS RELEASED TWO ALBUMS AS A COMPOSER AND SINGER.

Who really are you?

_A person who has fun designing appealing objects.

What do you think of when you hear the word plastic?

_It suggests the possibility of creating beautiful forms with sometimes surprising results.

What is your favorite color?

_It depends what it's for. Black for clothes, white for tableware, other objects could use a spectrum of colours.

Which Vondom item from another designer would you put in your home?

_Cono Fang pots.

What would you prefer, Classic or Science Fiction movie?

_I prefer thriller movies.

Do you have any *fetish* object?

_I don't think I have any.

What was the last thing you bought?

_A Macbook pro laptop.

Do you believe in perfection?

_ I believe in dedication and hard work to try to create perfect objects, although the final result will never be perfect.

Do you have any fixation or quirky habit?

_ I hate noise.

What do you do when you are not designing?

_ I compose music.



FLAT

COLLECTION BY
JORGE PENSI DESIGN STUDIO

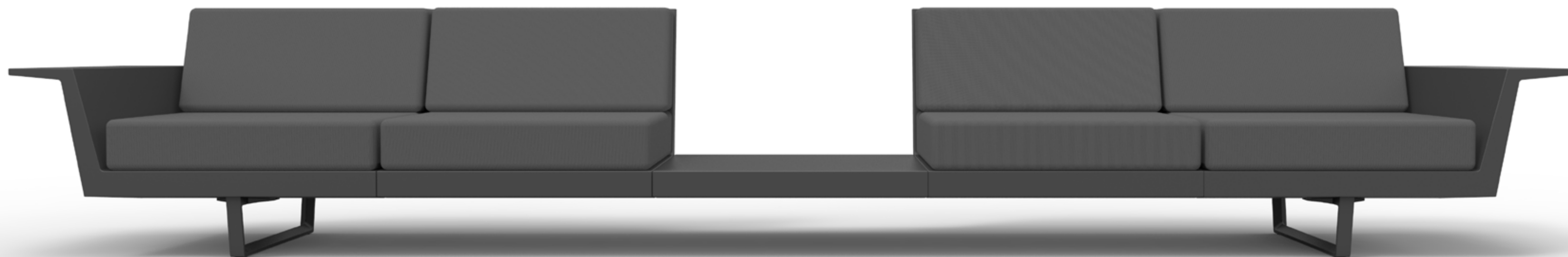

The FLAT Collection is made up of various pieces that can be used to form exterior lounge areas, but are also adequate for interior ones, thanks to their neutral shapes that are still full of identity. One of the characteristics of this set is that it looks light, because it rests on the floor on beautifully formed aluminium legs which give the object an appearance of virtually floating.

Another distinctive characteristic is the side table joined to the main unit, which at the same time is an armrest and a surface to lean on. Its build allows for making different combinations of pieces, to adapt them freely to any architectural space. With the corner unit it is easy to fit into angular spaces.

New Collection

FEATURES
COLORS
FINISHED



VONDOM®

Features Características
Colors Colores
Finished Acabados

FEATURES _Material PE

- Material: LLDPE Resin. Low density linear polyethylene. UL94 HB.
- Process: Rotational Moulding.
- Resistant to UVI. Factor UV8, equivalent to 8.000 hours of Florida sunLight.
- Resistant to extreme temperatures (-60°C to + 80°C) / (-76°F to 176°F)
- Shock Resistant.
- Light weight
- The planters are easily drilled to make drain holes.
- Recyclable 100%.

FEATURES _Lightning

LIGHT

EU: - VOLT 220-240V ~ 50 - 60Hz

- WATT: E27 18-30W
- Plug type: 
- CE
- RoHS
- Cord Length: 3 m / 118"
- Lamp Type: CFL
- IP65

USA: - VOLT. 110-120V ~ 60Hz

- WATT: E26 18-30W
- Plug type: 
- RoHS
- Wire Length: 3 m / 118"
- Lamp Type: CFL
- IP65

RGB LED

- LED lighting system.
- Color charge by remote control.
- Seven color combinations: white / yellow / green / red / Light blue / blue / pink.
- Dimmer
- 100-240V ~ 50-60Hz
- 350-400 LM
- IP65
- 18 - 72 W
- Long lasting.

NANO RGB LED WITH BATTERY

- LED lighting system.
- Color charge. Five color red / blue / green / white / violet
- Waterproof include: Clase IPX8. 2 meters
- Charger(included) Input 100-240V AC - 50-60 Hz 150mA /Output 4,2V DC 250 mA
- Battery (included): Li-Ion 3,7 V 700mAh
- Autonomy: 5-6h

NANO LED (EU)

- VOLT. 220-240V ~ 50 - 60Hz
- Cord Length: 2 m / 78" (with switch)
- Lamp Type: White LED (Ice)
- CE
- Indoor use only.

PACK _Battery + Charger

6500mAh Battery System

- Battery system. Autonomy: 5-6h
- Charger (included) Input 100-240V AC - 50-60 Hz 350 mA / Output 12V DC
- Battery (included): 12V - 6500mAh. / Load: 5h / 500 cycles

17Ah Battery System

- Battery system. Autonomy: 5-6h
- Charger (included) Input 100-240V AC - 50-60 Hz 2000-4000 mA / Output 12V DC
- Battery (included): 12V -17Ah. / Load: 8h / 500 cycles

PACK _Bluetooth Sound System

Connect your smartphone or tablet via Bluetooth to the built in speakers.

- Sound systems 150W Dual component.
- Bluetooth Ready.
- Input: AUX Jack 3,5 mm.
- USB Charger for portable gadget - Output 5V= 1500mA

FEATURES _Foam

Padded foam used in the products.

Density: 30/40 Kg/m² - Plasticized: Yes

FEATURES _Table Tops

FULL WHITE (SOLID SURFACE)

Solid Surface is a solid surface made of long lasting resins and mineral fillers. It is maintenance free and has a maximum resistance to scratches and stains. This board has the ISO 19172 certification, which ensures its highest quality.

Features	Specialization	Test Method
Radiant heat Resistance	600 seconds	Nema LD 3-3. 10
Thermal Expansion	< 5,4•105 mm/mm° C	ASTM E 228 m
Flexure Strength	> 27,8 MPa	ASTM D 790
Flexural Modulus	> 6895 MPa	ASTM D 790
Hardness Barcol	50-70	ASTM D 2583
Planarity	< 160 mm	ISSFA SST 4,1-00
Impact Strength	Pass at 1525 mm	ISSFA SST 6,1-00
Behaviour of microorganism	No growth	ASTM G21
Bacterie Resistance	No growth	ASTM G21
Consistency of color	Pass	ISSFA SST 2,1-00
Stain Resistance	< 52	ISSFA SST 3,1-00
Visula Defect	Pass	ISSFA SST 5,1-00
Light fastness	Without effect	ISSFA SST 7,1-00
Resistance to boiling water	Without effect	ISSFA SST 8,1-00
High temperature resistance	Without effect	ISSFA SST 9,1-00

HPL

HPL tabletops are made out of paper layers agglutinated with thermoset resins of Melamine-Formaldehyde on the surface and Phenol-Formaldehyde inside. Everything is pressed at high temperature and pressure. Suitable for indoor and outdoor.

Features	Method	Units	Value	
Thickness	ISO 4586 ½	mm	13 ± 0,55	
Density	ISO 1183	Kg/m³	1400 - 1500	
Water Absorption	ISO 4586 ½	%	Weight	2,0 max.
			Thickness	2,0 max.
Dimensional Stability to High Temperatures	ISO 4586 ½	%	Long.	0,25 max.
			Trans.	0,55 max.
Hardness	ASTM D 785	HR E	97 ca	
Flexion Resistance	ISO 178	MPa MPa	Long	145 min.
			Trans	135 min.

GLASS

10 mm. Security temperate glass.

Technical Features	Units	Value
Resistance to soft body impact		2(B)2
Resistance against suddn temperature changes and temperatures differentials	K	40
Resistance to wind, snow and imposed load.	mm	10
Care direct airborne sound insulation	dB	34 (-1,-3)
Thermal Properties		
Thermal Transmittance (value U)	W/(m2,K)	5,6
Radatin properties		
Transmition Light tV		0,53
Light Refletionm pV		0,06/0,06
Solar Transmission tE		0,52
Solar Reflection pE		0,06/0,06

Glass



HPL black edge / borde negro

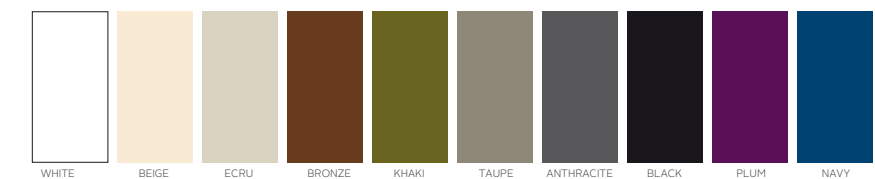

Full White

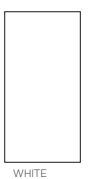

FEATURES _Fabrics

NAUTICAL

Soft leather like fabric suitable for indoor and outdoor. Standard option for upholstery.

Composition	Vinyl / 100%Polyester HiLoft
Weight	780 gr/m²
Abrasion	>120.000 cycles
Fire Retardancy	EN 1021 (Parts 1 - 2) - M2 (NF P 92.507) BS 5852 - DIN 53438/T2
Cold Crack	-20°C
UV Resistance	1000 hours / Factor 7UV
Antibacterial Treatment	Yes
Outdoor Using	Yes

SILVERTEX

Vinyl fabric suitable for indoor and outdoor. Special option for upholstery.

Composition	Vinyl / 100%Polyester HiLoft
Weight	685 gr/m²
Abrasion	>300.000 cycles (Martindale)
Fire Retardancy	EN 1021 (Parts 1 - 2) - DIN 4102 B2 - NF P 92-503 / M2 UNE 23.727-90 IR/ M2 - IMO A.652 (16) annex 1, 8.2&8.3
Cold Crack	-23°C
UV Resistance	1000 hours / Factor 7UV
Antibacterial Treatment	Yes
Outdoor Using	Yes

KINNASAND®

Vinyl fabric suitable for indoor and outdoor. Special option for upholstery.

Composition	Vinyl / 100%Polyester HiLoft
Weight	685 gr/m²
Abrasion	>300.000 cycles (Martindale)
Fire Retardancy	EN 1021 (Parts 1 - 2) DIN 4102 B2 - NF P 92-503 / M2 UNE 23.727-90 IR/ M2 - IMO A.652 (16) annex 1, 8.2&8.3
Cold Crack	-30°C / +70°C
UV Resistance	1000 hours / Factor 7UV
Antibacterial Treatment	Yes
Outdoor Using	Yes

BATYLINE®

Woven polyester fibre protected by a PVC coating. Suitable for indoor and outdoor. Only available for Daybed Faz parasol.

Composition	Polyester / PVC Composite
Weight	500 gr/m²
Abrasion	SC (very heavy use)
Fire Retardancy	EN 1021 (Parts 1 - 2) - DIN 4102 B1 - NFP 92-503/M2 B-S2-Do - NF-EN 13501-1 - OMI A.652 (part 16) CAL TB N° 117 -2000 Section E, Part 1
Extreme working temperatures	-30°C / +70°C
UV Resistance	ΔE lab < 3 UVA 340 / 2000 hours
Antibacterial Treatment	Yes
Outdoor Using	Yes

FABRICS TELAS

NAUTICAL

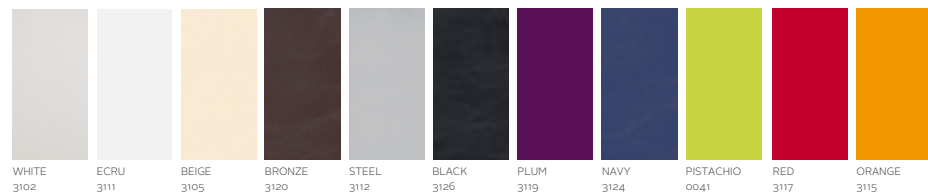

SILVERTEX

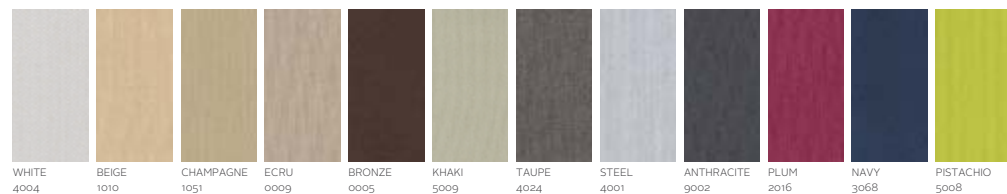

BATYLINE only Daybed Faz

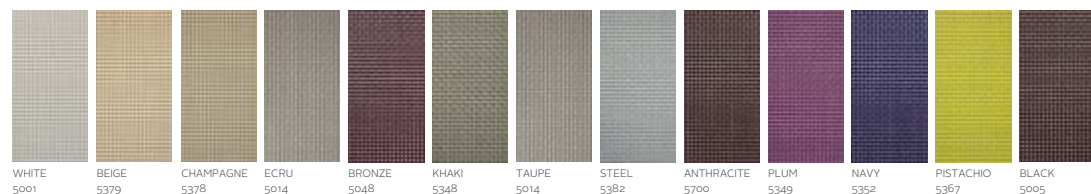

KINNASAND

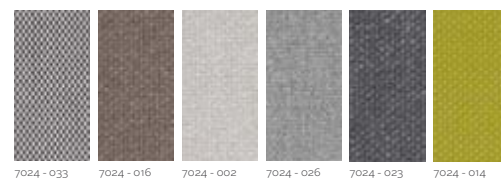

DMX WIRELESS

DMX 512 (Digital Multiplex) is a protocol used for the electronic control for entertainment lighting, enabling communication between the table-control, their own lights and light sources.

You can create customized and special environments. Allow to control every Vondom product independently or in groups.

There are 2 different DMX Wireless, depending on customer needs.

_DMX WIRELESS PROFESSIONAL XLR PACK

Vondom DMX Wireless Professional XLR you can control all LED RGB VONDOM pieces with your Mix Tables, PC+software, Domotic panels, etc.

1* DMX Wireless Standard Configuration

We will preset three separately Family products: POTS, LAMPS & FURNITURE.

2* DMX Wireless Customized Configuration

You can send us your customized special environment that you want to control independently and we will set it up.

DMX WIRELESS PROFESSIONAL XLR PACK

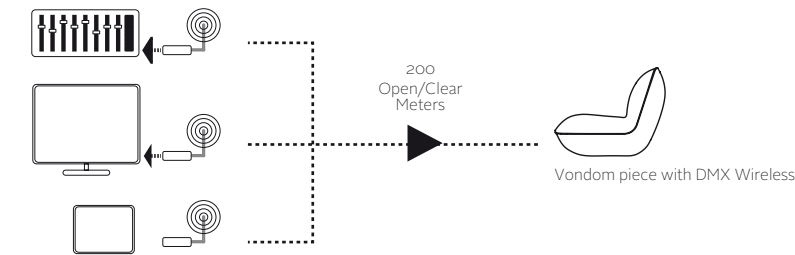

1* DMX Wireless Professional Standard Configuration

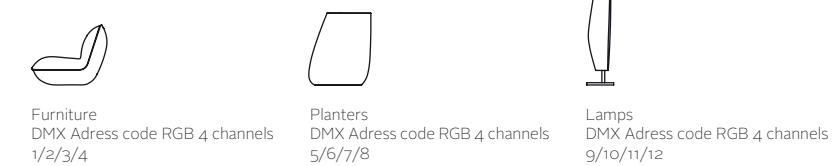

2* DMX Wireless Professional Customized Configuration

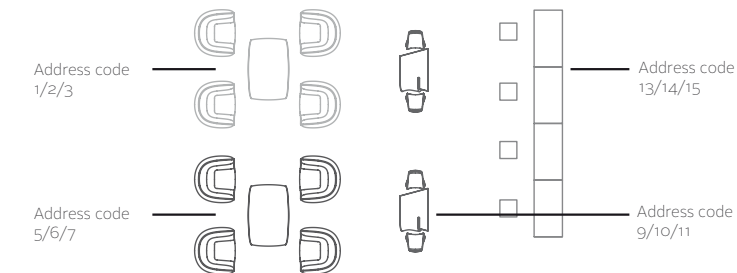

_DMX WIRELESS HOME WIFI PACK

Vondom DMX Wireless Home Wi-Fi Pack is a Wi-Fi access point to control all LED RGB VONDOM items with your IOS or Android devices.

1* DMX Wireless Standard Configuration

We will preset three separately Family products: PLANTERS, LAMPS & FURNITURE.

2* DMX Wireless Customized Configuration

You can send us your customized requirements in order to control individually each item/group and we will set it up. (Max. 8 rooms)

DMX WIRELESS HOME WIFI PACK

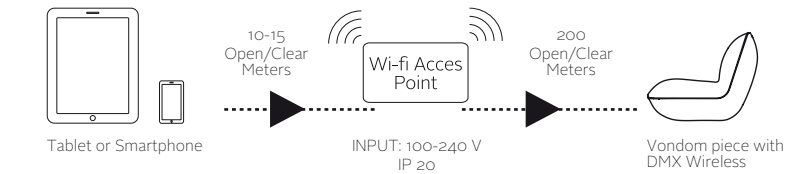

1* DMX Wireless Home Standard Configuration



2* DMX Wireless Home Customized Configuration

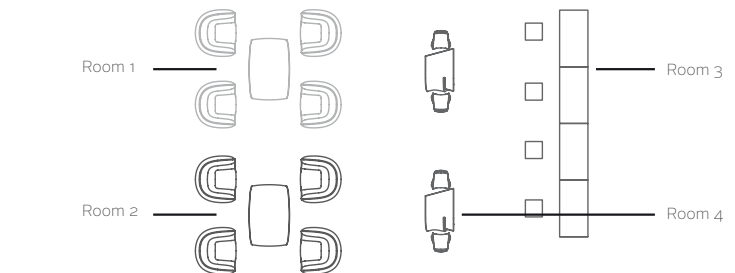

FINISHING _Furniture

Furniture made out of polyethylene resin with double wall. Item suitable for indoor and outdoor use.

_BASIC

Matt finishing.

_LACQUERED

Gloss lacquered finishing.

_LIGHT

Ice color finishing. White lighting inside by means of energy saving lamps.

_RGB LED

Ice color finishing. Includes RGB Led lightning system and a remote control to program the color option*.

_RGB LED DMX

Ice color finishing. Includes RGB Led lightning system. Controlled by DMX 512 Wireless, enabling communication between the table-control, their own lights and light sources*.

_TWO-TONE

Matt finish in two different colors. Colors available according to the collections.

_TWO-TONE LACQUERED

Gloss lacquered finishing in two different colors. To avoid possible damage is not recommended stacking the product.

_KIDS

Furniture suitable for children over 3 years.

*7 colors: white, red, green, blue, Light blue, pink and yellow.

FINISHING _Nano

Mini flowerPlanter made out of polyethylene resin, with Basic. Item suitable for indoor and outdoor use.

_NANO BASIC

Matt finishing.

_NANO LACQUERED

Gloss lacquered finishing.

_NANO LED

White Lighting inside by means of led. Item suitable ONLY for indoor use.

_NANO RGB LED WITH BATTERY

Lighting inside by means of RGB Led tecnology*. Charger and battery included.

*5 Colors LED: red/blue/green/white / violet

FINISHING _Planters

Planter made out of polyethylene resin with double wall. Item suitable for indoor and outdoor use.

_SIMPLE

Pot with simple wall, mat finishing.

_LACQUERED SIMPLE

Pot with simple wall, lacquered finishing.

_BASIC

Matt finishing.

_SELF-WATERING

Matt finishing planter with self-watering system.

_LACQUERED

Gloss lacquered finishing with self-watering system.

_LIGHT

Ice color finishing planter with self-watering system. White lighting inside by means of energy saving lamps.

_RGB LED

Ice color finishing planter with self-watering system. Includes RGB Led lightning system* and a remote control to program the colors option.

_RGB LED DMX

Ice color finishing. Includes RGB Led lightning system*. Controlled by DMX 512 Wireless, enabling communication between the table-control, their own lights and light sources. —

*7 colors: white, red, green, blue, Light blue, pink and yellow.

Colors COLORS

_Matt

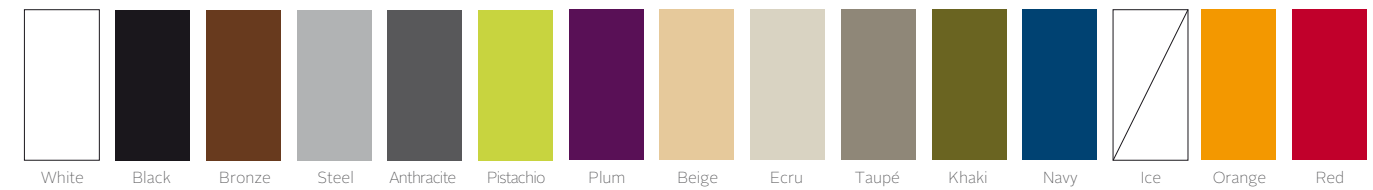

_Lacquered

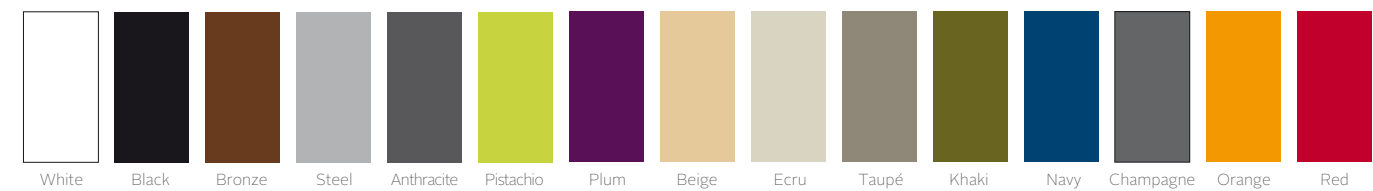

_Two-Tone Lacquered



MAINTANENCE & SAFETY

Our production is made according to the quality guide ISO 9001:2008 and of environment ISO 14001:2004, by using only materials of high quality to guarantee a long useful life of the products.

In order to provide a durable and safe use to the product, please follow the following recommendations:

- All our products are suitable for indoor and outdoor use.
- The continuous exposure to the sun (especially for the dark colors) can cause burning injuries by direct contact with your skin. To avoid this, please check the temperature of the furniture in case of long-term exposure to the strong sun.
- Place the item on a flat surface without inclination to avoid uncontrolled movements.
- Keep the item far from excessive heat sources.
- The product is not a toy. To avoid accidents, do not to allow children to play with it.
- Keep furniture away from sources of dust to keep it clean. In the case of required cleaning, it is recommended the use of pressure washers, such as KARCHER machines and/or domestic degreasing cleaner periodically. Never use abrasive or corrosive products.
- To preserve the product, it is recommended to use a VONDOM cover for every item.
- For lacquered products, it is recommended to use car wax every 2 or 3 months, as it will avoid the appearance of possible scratches.
- Outdoor cushions are available for some models. It is recommended to clean them periodically by using a cloth with neutral soap and water.
- Clean the stainless steel part with appropriate products.
- When changing the bulb, please make sure the cord is not connected to the main power.
- If the cord suffers any damage, it must be exchanged exclusively by the manufacturer or by a professional.
- If the RGB Led stops working, please do not handle it. Contact the manufacturer or the dealer immediately.

CLEANING

Vondom Outdoor Furniture cleans easily and stays impeccable.

Steps for clean outdoor furniture:

1. Spray the degreaser over the dirty surface.
2. Rub it with a damp cloth.
3. Rinse with abundant water with pressure washer.

Cautions! Don't use pressure washer for cushions and lacquered finish items.

4. Dry it outside and enjoy your products.

- We hope you enjoy our products. If you need any further information, please do not hesitate to contact our CUSTOMER SERVICE department by calling +34 96 239 84 86 or sending an e-mail to info@vondom.com.

OUTDOOR RUG

MAINTANENCE & SAFETY

Our production is made according to the quality guide ISO 9001:2008 and of environment ISO 14001:2004, by using only materials of high quality to guarantee a long useful life of the products.

In order to provide a durable and safe use to the product, please follow the following recommendations:

- All our products are suitable for indoor and outdoor use.
- Highly resistant to UV rays
- It is not to heat sources, it may melt if the temperature rises more than 80°C.
- Any improper use may be harmful to itself.

CLEANING

The dirt must be eliminated by a short sprinkling or with a simple cleaning with a hose.

To avoid the squashing of the fibres, it should be brushed against the nap so that the fibres recover their vertical position.



TECHNICAL FEATURES

Product designed by soft and resistant to UV rays Polyethylene fibers.

YARN	
Type	Fibrillated
Composition	Polyethylene
TUFTING	
Finishing	Cut Pile
PRIMARY BACKING	
Type	Reinforced Fleece
Composition	Polypropylene
Weight	165 gr/m²
FINISHING	
Composition	Polyurethane drilled to not retain water and liquids.
FINAL PRODUCT	
Total Height	18 mm (±5%)

RUG SECTION



VONDOM®

Collections
Dimensions
Colecciones
Medidas

+ / - 1m

ALMA
by A-cero

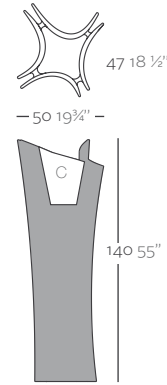

	L	C (d x h) cm	Self-Watering	Lacquered	Light	RGB Led	RGB Led DMX
Alma	10 2/4	20 x 24 7 3/4" x 9 1/2"	53013 ^b	53013F	53013W ^a	53013L ^a	53013D ^b

b_ self-watering included.
i_ possibility of transparent cord & switch for indoor.
b_ incluye sistema de autorriego.
i_ posibilidad de cable transparente e interruptor para interior.

MORA
by Javier Mariscal

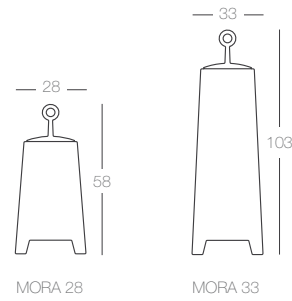

	Light	RGB Led	RGB Led DMX
MORA 28	46028W	46028L	46028D
MORA 33	46033W	46033L	46033D

i_ possibility of transparent cord & switch for indoor.
i_ posibilidad de cable transparente e interruptor para interior.

BLANCA
by Javier Mariscal

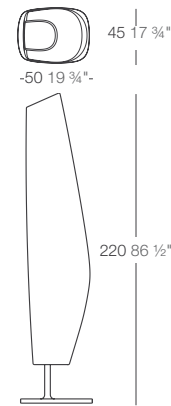

BLANCA Lámpara
BLANCA Lamp

	White Led	RGB Led	RGB Led DMX
BLANCA	46050W	46050L	46050D

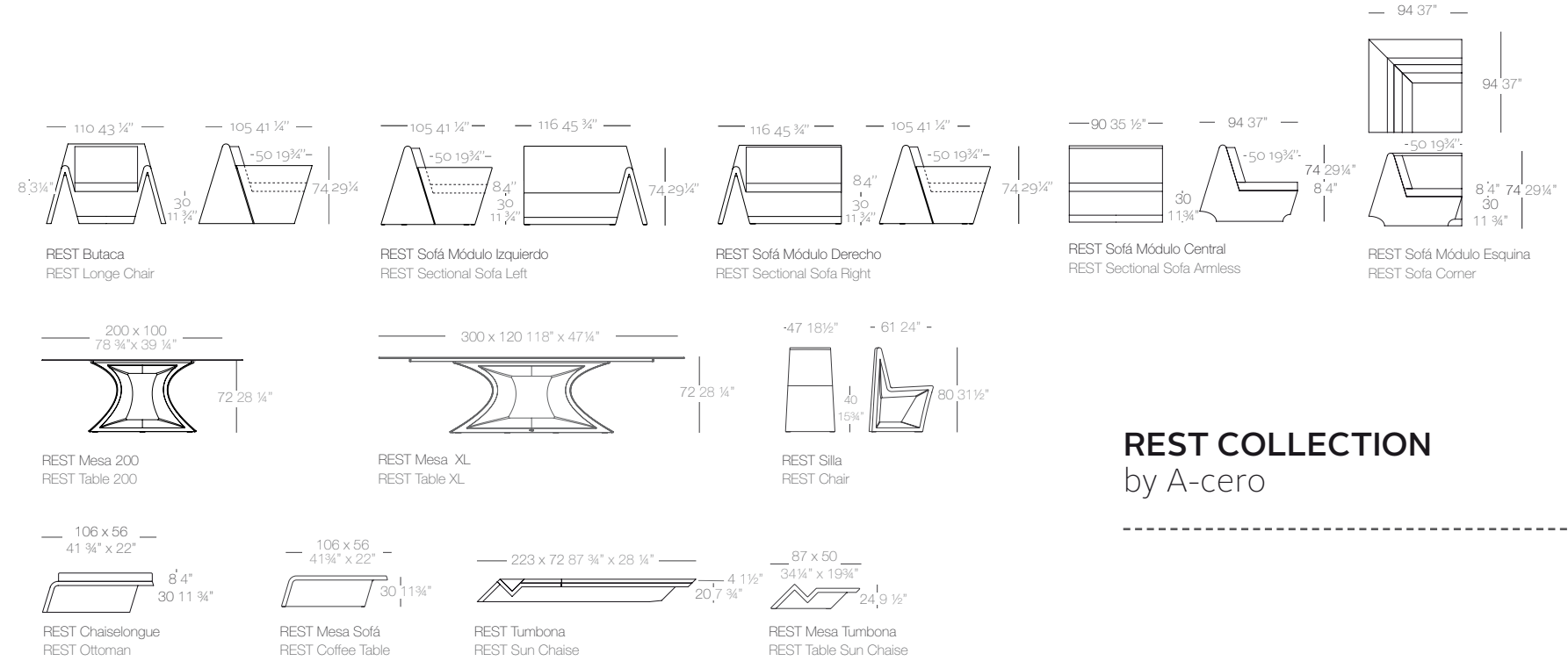

REST COLLECTION
by A-cero

	Lounge Chair Butaca	Sofa Left M. Izq	Sofa Right M. Dch	Sofa Armless M. Central	Sofa Corner M. Esquina	Ottoman Chaiselongue	Coffee Table Mesa sofá	Sun Chaise Tumbona	Table Sun Chaise Mesa Tumbona	Table 200 Mesa 200	Table XL Mesa XL	Chair Silla
Basic	53001* ^t	53002* ^{to}	53003* ^{to}	53004* ^{to}	53005* ^{to}	53006* ^t	53007 ^t	53008* ^{am}	53009 ^t	53010 ^t	53011 ^t	53012 ^t
Lacquered	53001F* ^t	53002F* ^{to}	53003F* ^{to}	53004F* ^{to}	53005F* ^{to}	53006F* ^t	53007F ^t	53008F* ^{am}	53009F ^t	53010F ^t	53011F ^t	53012F ^t
Light	53001W* ^t	53002W* ^{to}	53003W* ^{to}	53004W* ^{to}	53005W* ^{to}	53006W* ^t	53007W ^t	53008W* ^{am}	53009W ^t	-	-	-
White Led	-	-	-	-	-	-	-	-	-	53010W ^t	53011W ^t	-
RGB Led	53001L* ^t	53002L* ^{to}	53003L* ^{to}	53004L* ^{to}	53005L* ^{to}	53006L* ^t	53007L ^t	53008L* ^{am}	53009L ^t	53010L ^t	53011L ^t	-
Basic / Solid Surface	-	-	-	-	-	-	-	-	-	53010B ^t	53011B ^t	-
Lacquered / Solid Surface	-	-	-	-	-	-	-	-	-	53010FB ^t	53011FB ^t	-
Light / Solid Surface	-	-	-	-	-	-	-	-	-	53010WB ^t	53011WB ^t	-
RGB Led / Solid Surface	-	-	-	-	-	-	-	-	-	53010LB ^t	53011LB ^t	-
Basic / Glass	-	-	-	-	-	-	-	-	-	53010G ^t	53011G ^t	-
Lacquered / Glass	-	-	-	-	-	-	-	-	-	53010BG ^t	53011BG ^t	-
Light / Glass	-	-	-	-	-	-	-	-	-	53010WG ^t	53011WG ^t	-
RGB Led / Glass	-	-	-	-	-	-	-	-	-	53010LG ^t	53011LG ^t	-
Cushion Colchoneta	-	-	-	-	-	-	-	-	-	-	-	53012CO

*_ cushions are included in the prize
a_ wheels included
t_ non-slipping feet included
m_ moving headrest
e_ join set in order to fix them together

*_ acolchados incluidos en el precio
a_ incluye ruedas
t_ incluye tacos antideslizantes
m_ cabeza móvil
e_ incluye un set de ensamblaje para fijarlos entre ellos

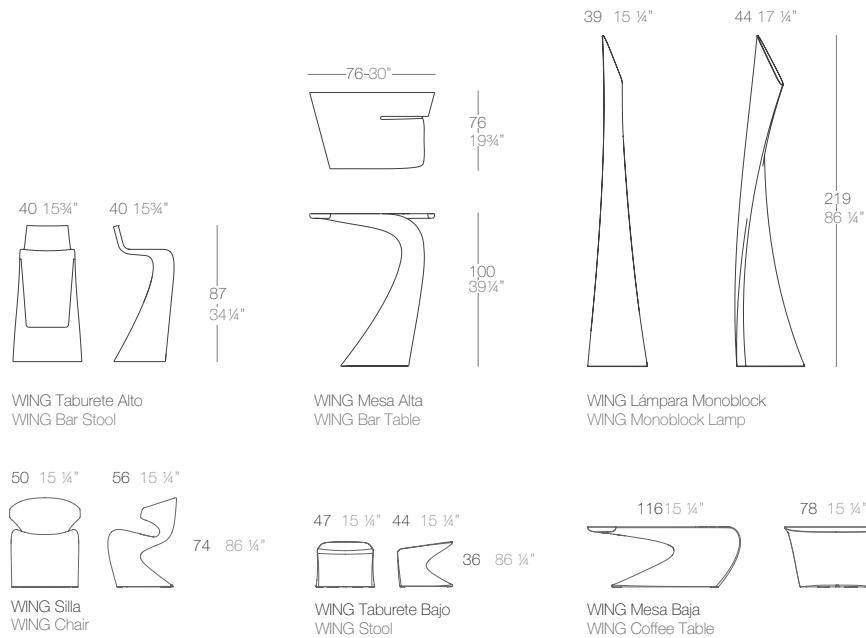

WING COLLECTION

by A-cero

	Basic	Lacquered	Light	RGB Led	RGB Led DMX
Taburete Bar Stool	53031	53031F	53031W ^a	53031L ^b	53031D ^c
Mesa Alta Bar Table	53032	53032F	53032W ^a	53032L ^b	53032D ^c
Lámpara Lamp	-	-	53033W ^a	53033L ^b	53033D ^c
Taburete Bajo Stool	53036	53036F	53036W ^a	53036L ^b	53036D ^c
Mesa Baja Coffee Table	53035	53035F	53035W ^a	53035L ^b	53035D ^c
Silla Chair	53034	53034F	53034W ^a	53034L ^b	53034D ^c

MOMA

by Javier Mariscal

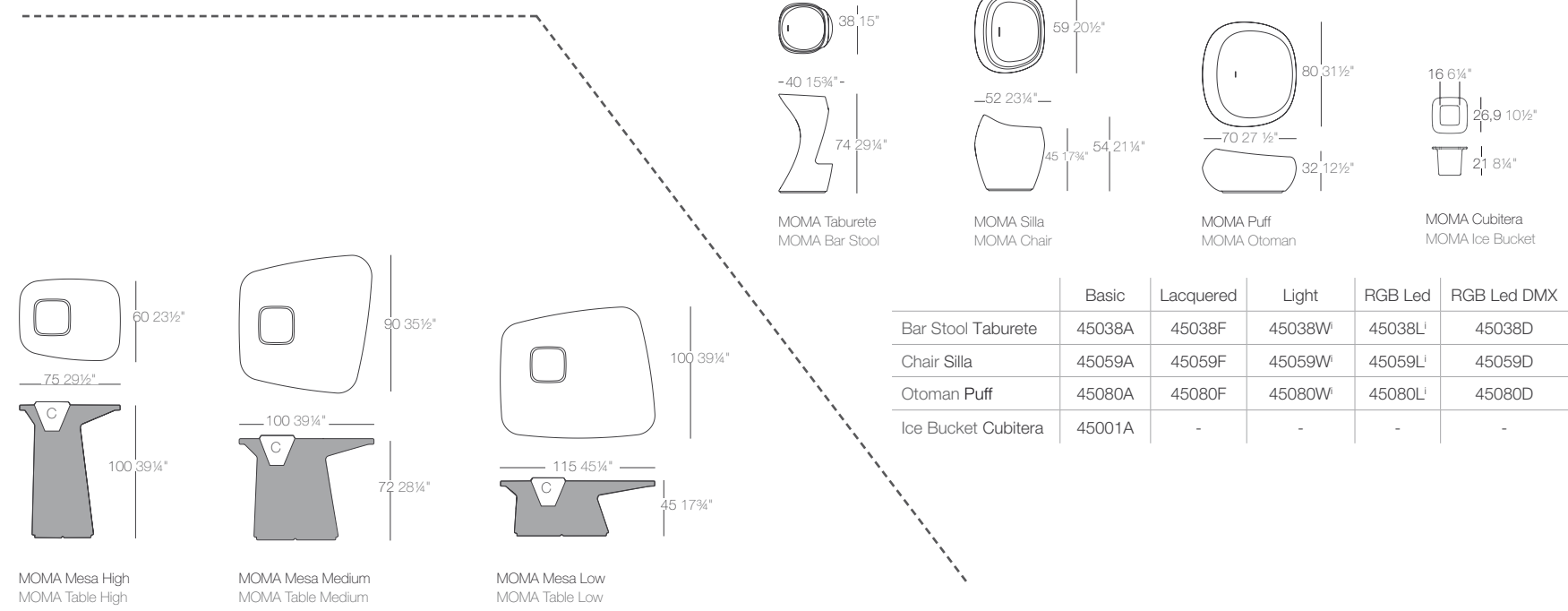

	Basic	Lacquered	Light	RGB Led	RGB Led DMX
Bar Stool Taburete	45038A	45038F	45038W ^a	45038L ^b	45038D ^c
Chair Silla	45059A	45059F	45059W ^a	45059L ^b	45059D ^c
Otoman Puff	45080A	45080F	45080W ^a	45080L ^b	45080D ^c
Ice Bucket Cubitera	45001A	-	-	-	-

SABINAS COLLECTION

by Javier Mariscal

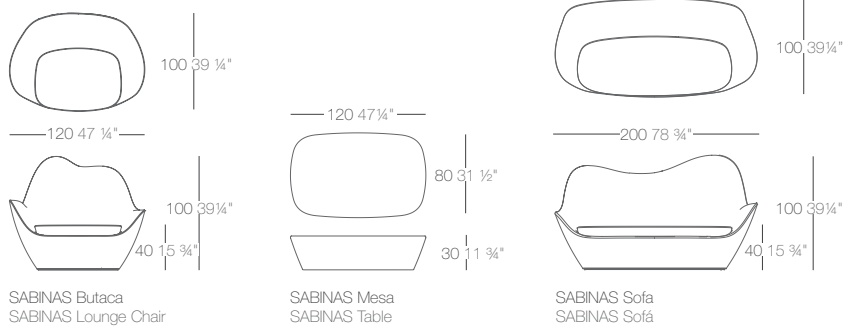

	Basic	Lacquered	Light	RGB Led	RGB Led DMX	Top Cubre
Lounge Chair Butaca	45007	45007F	45007W ^a	45007L ^b	45007D ^c	-
Table Mesa	45008	45008F	45008W ^a	45008L ^b	45008D ^c	45008C
Sofa Sofa	45009	45009F	45009W ^a	45009L ^b	45009D ^c	-

^a Grosor Acollchado Butaca/Sofa: 8 cm
^b Thick Cushion ArmChair/ Sofa: 10 cm / 4"

MOMA MELLIZAS COLLECTION

by Javier Mariscal

	L Gal	C (d x d') x h cm in	Basic	Self-Watering	Lacquered	Light	RGB Led	RGB Led DMX
High	42 11	(37x29)x39 14½"x11½"x15¼"	45002A	45002R	45002F	45002W ^{bi}	45002L ^{bi}	45002L ^b
Low	63 16 ¾	(44x37)x39 17¼"x14½"x15¼"	45003A	45003R	45003F	45003W ^{bi}	45003L ^{bi}	45003L ^b

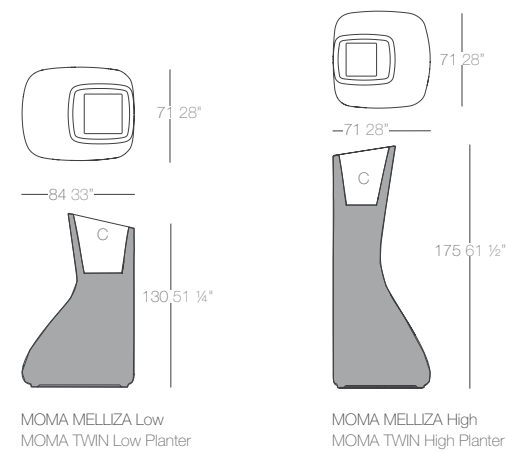

MOMA MACETAS

by Javier Mariscal

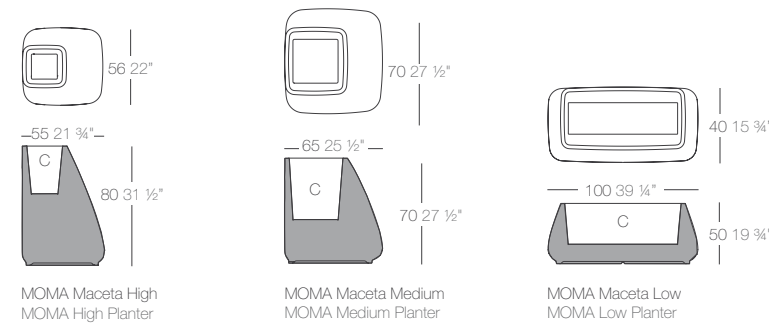

	L Gal	C (d x d') x h cm in	Basic	Self-Watering	Lacquered	Light	RGB Led	RGB Led DMX
High	29 7¾	(52x39)x26 20½"x15½"x10"	45005A	45005R	45005F	45005W ^{bi}	45005L ^{bi}	45005D ^b
Medium	48 7¾	(30 x30)x32,5 12"x12"x13"	45004A	45004R	45004F	45004W ^{bi}	45004L ^{bi}	45004D ^b
Low	76,5 20¼	(36,5x77,5)x27 14½"x30½"x10½"	45006A	45006R	45006F	45006W ^{bi}	45006L ^{bi}	45006D ^b

b_ self-watering included.
 L_ possibility of transparent cord & switch for indoor.
 b_ incluye sistema de autorriego.
 L_ posibilidad de cable transparente e interruptor para interior.

VERTEX COLLECTION

by Karim Rashid

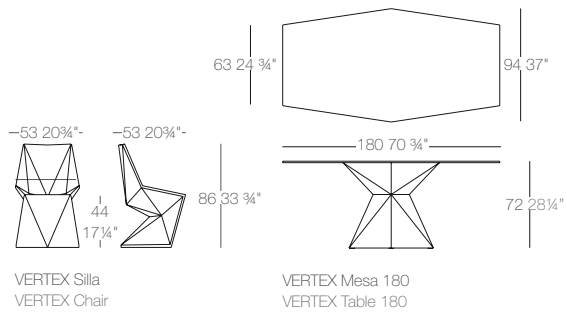

	Basic	Lacquered	Light	RGB Led	RGB Led DMX	Cushion Acolchado	Basic/ Glass	Lacquered/ Glass	White Led/ Glass	RGB Led/ Glass
Chair Silla	51007	51007F	51007W	51007L	51007D	51007CO	-	-	-	-
Table 180 Mesa 180	51008	51008F	51008W	51008L	51008D	-	51008G	51008FG	51008WG	51008LG

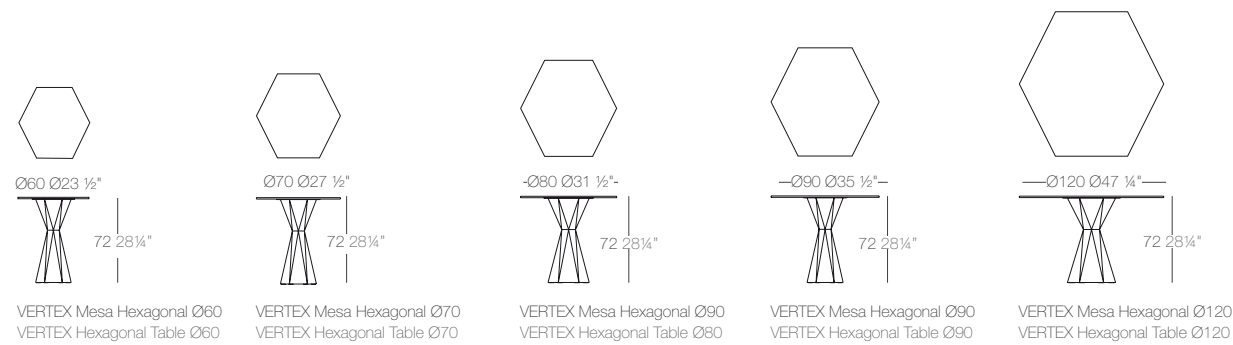
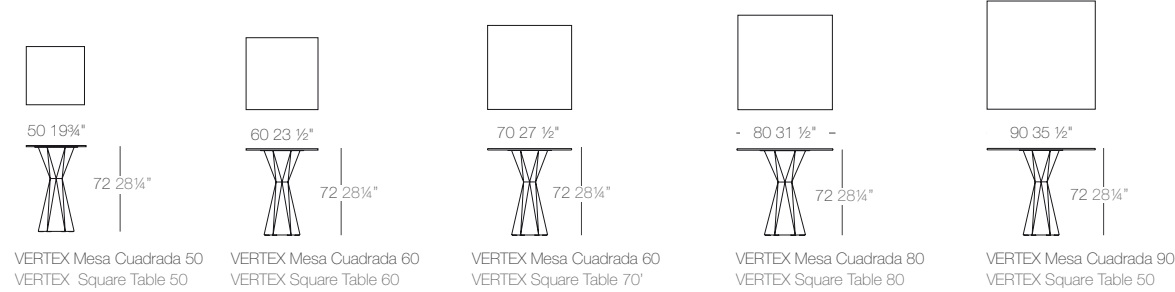

	Table 50 Mesa 50	Table 60 Mesa 60	Table 70 Mesa 70	Table 80 Mesa 80	Table 90 Mesa 90	Table H 60 Mesa H60	Table H 70 Mesa H70	Table H 80 Mesa H80	Table H 90 Mesa H90	Table H 120 Mesa H120
Basic	51017C	51010C	51009C	51019C	51018C	51010E	51009E	51019E	51018E	51020E
Lacquered	51017CF	51010CF	51009CF	51019CF	51018CF	51010EF	51009EF	51019EF	51018EF	51020EF
Light	51017CW	51010CW	51009CW	51019CW	51018CW	51010EW	51009EW	51019EW	51018EW	51020EW
RGB Led	51017CL	51010CL	51009CL	51019CL	51018CL	51010EL	51009EL	51019EL	51018EL	51020EL
RGB Led DMX	51017CD	51010CD	51009CD	51019CD	51018CD	51010ED	51009ED	51019EL	51018ED	51020ED

*Thick Board Tables: 12 mm / 1/2" Grosor tablero: 12 mm

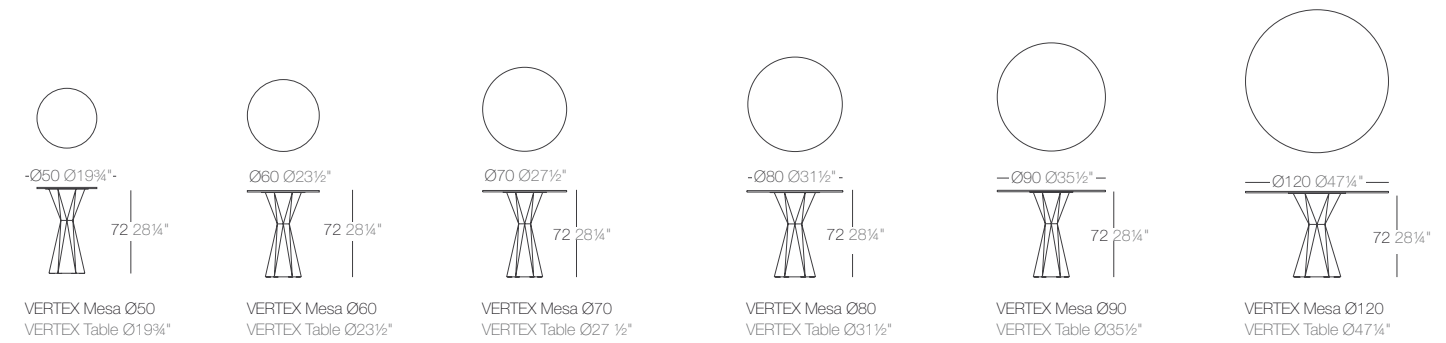
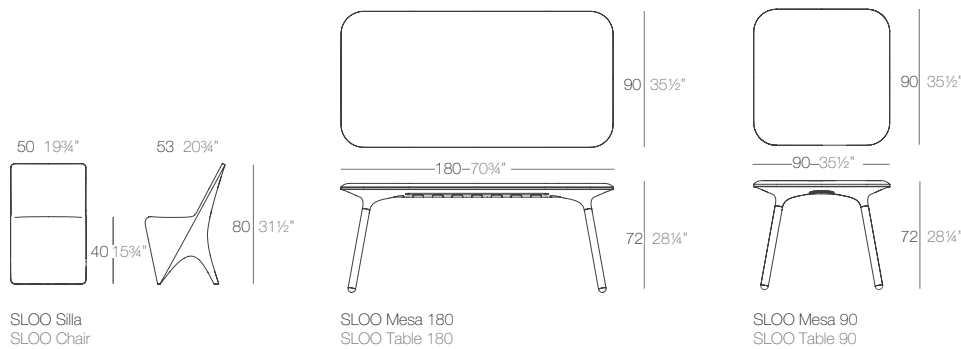

	Table Ø19 1/4" Mesa Ø50	Table Ø23 1/2" Mesa Ø60	Table Ø27 1/2" Mesa Ø70	Table Ø31 1/2" Mesa Ø80	Table Ø35 1/2" Mesa Ø90	Table Ø47 1/4" Mesa Ø120
Basic	51017	51010	51009	51019	51018	51020
Lacquered	51017F	51010F	51009F	51019F	51018F	51020F
Light	51017W	51010W	51009W	51019W	51018W	51020W
RGB Led	51017L	51010L	51009L	51019L	51018L	51020L
RGB Led DMX	51017D	51010D	51009D	51019D	51018D	51020D

SLOO COLLECTION

by Karim Rashid



	Basic	Lacquered	Cushion Acolchado
Chair Silla	51025	51025F	51024 CO
Table 90 - Stainless Steel Legs Mesa 90 - Patas Acero Inoxidable	51026	51026F	-
Table 180 - Stainless Steel Legs Mesa 180 - Patas Acero Inoxidable	51027	51027F	-
Table 90 - Wood Legs Mesa 90 - Patas Madera Iroko	51028	51028F	-
Table 180 - Wood Legs Mesa 180 - Patas Madera Iroko	51029	51029F	-

PAL COLLECTION

by Karim Rashid

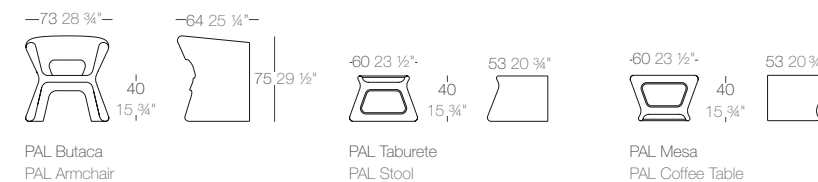

	Basic	Lacquered	Light	RGB Led	RGB Led DMX	Cushion Acolchado*
Armchair Butaca	51005	51005F	-	-	-	51005CO
Stool Taburete	51006	51006F	51006W	51006L	51006D	-
Coffee Table Mesa	51006	51006F	51006W	51006L	51006D	-

*Thick Cushion ArmChair: 4 cm / 1 1/2" Grosor Acolchado Butaca: 4 cm

L possibility of transparent cord & switch for indoor.
L posibilidad de cable transparente e interruptor para interior.

DIMENSIONS DIMENSIONES

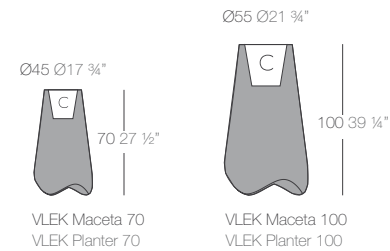

	L Gal	C (Ød x h) cm in	Basic	Lacquered	Nano Led
Nano 28	1 ¼	Ø7 x 14 Ø2¾" x 5½"	51015A	51015F	51015W
Nano 36	2 ½	Ø9 x 19 Ø3½" x 7½"	51016A	51016F	51016W

	L Gal	C (Ød x h) cm in	Basic	Self-Watering	Lacquered	Light	RGB Led	RGB Led DMX
Maceta Planter 70	10 2 ¾	Ø24 x 24 Ø9½" x 9½"	51013A	51013R	51013F	51013W ^b	51003L ^b	51003D ^b
Maceta Planter 100	20 5 ½	Ø30 x 32 Ø11¾" x 12½"	51014A	51014R	51014F	51014W ^b	51004L ^b	51004D ^b

PASTA COLLECTION by Karim Rashid

	L Gal	C (d x h) cm in	Basic	Self-Watering	Lacquered	Light	RGB Led	RGB Led DMX
Kannelloni	25 6 ½	100 x 24 x 27 39¼" x 9½" x 10¾"	51024A	51024R	51024F	51024W ^b	51024L ^b	51024D ^b
Spaguetti	20 5 ½	Ø38 x 24 Ø15" x 9½"	51022A	51022R	51022F	51022W ^b	51022L ^b	51022D ^b

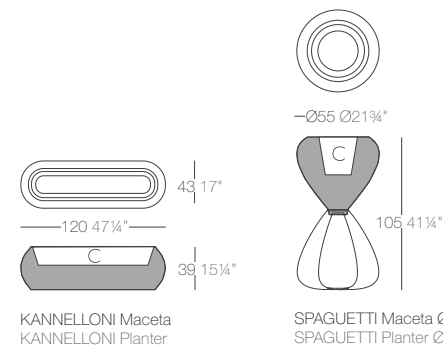

b_ self-watering included.
 L_ possibility of transparent cable & switch for indoor.
 b_ incluye sistema de autorriego.
 L_ posibilidad de cable transparente e interruptor para interior.

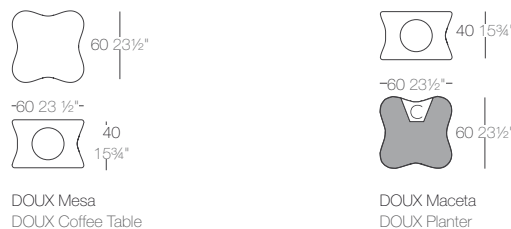
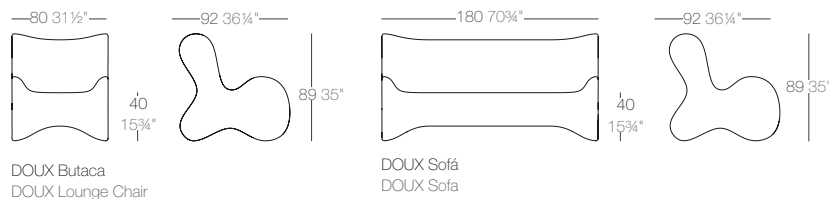

DOUX COLLECTION by Karim Rashid

	L Gal	C (Ød X h) cm in	Basic	Self-Watering	Lacquered	Light	RGB Led	RGB Led DMX
Lounge Chair Butaca	-	-	51001	-	51001F	51001W ^b	51001L ^b	51001D
Sofa Sofá	-	-	51002	-	51002F	51002W ^b	51002L ^b	51002D
Coffee Table Mesa	-	-	51003	-	51003F	51003W ^b	51003L ^b	51003D
Planter Maceta	10 2 ¾	Ø22 x 22 ø8¾" x 8¾"	-	51004R	51004F	51004W ^b	51004L ^b	51004D ^b

b_ self-watering included.
 L_ possibility of transparent cord & switch for indoor.
 b_ incluye sistema de autorriego.
 L_ posibilidad de cable transparente e interruptor para interior.

SURF COLLECTION by Karim Rashid

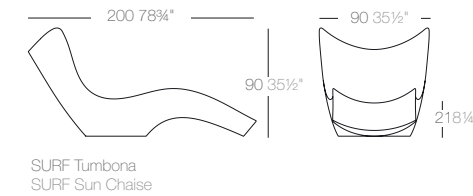

	Basic	Lacquered	Light	RGB Led	RGB Led DMX
Surf	51011	51011F	51011W ^b	51011L ^b	51011D

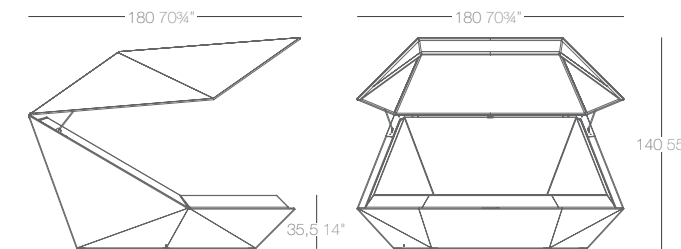

FAZ Daybed with parasol
 Abierto Open Cerrado Close 360° Giratorio 360° Rotation
 140 55" 90 35½"
 Thick Cushion Grosor Acollchado: 8 cm / 4"

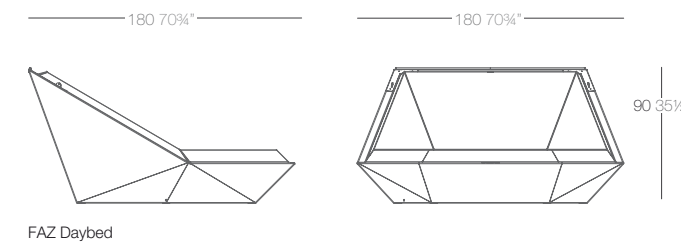

FAZ Daybed

LAVA COLLECTION by Karim Rashid

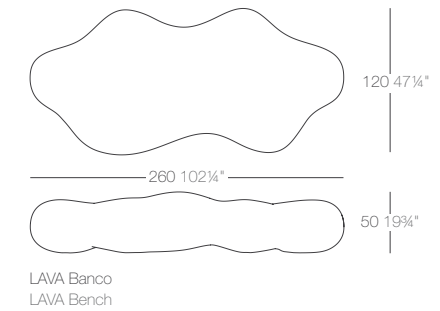

	Basic	Lacquered	Light	RGB Led	RGB Led DMX	KIT Colgante Ceiling Holder
Lava	51012	51012F	51012W ^b	51012L ^b	51012D	51012X

FAZ DAYBED COLLECTION by Ramon Esteve

	Daybed	Daybed with Parasol
Basic	54086	54098
Lacquered	54086F	54098F
Light	54086W	54098W
RGB Led	54086L	54098L

Extras	Ref
Pack Outdoor Bluetooth Sound System	54099
Pack Bateria + Cargador Pack Battery + Charger	54100
Pack 4 Cojines 60x60 cm 4 Pillows Pack 60 x 60 cm	54101

DIMENSIONS DIMENSIONES

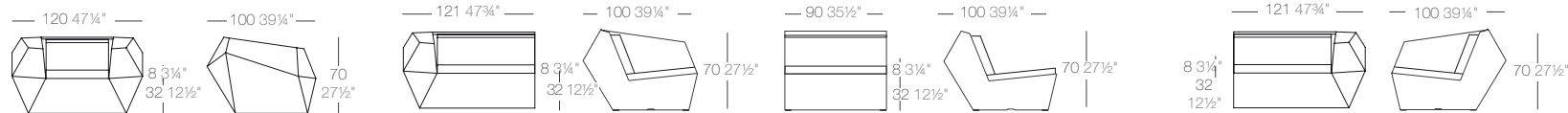

FAZ Butaca
FAZ Lounge Chair

FAZ Sofá Módulo Derecho
FAZ Sectional Sofa Right

FAZ Sofá Módulo Central
FAZ Sectional Sofa Armless

FAZ Sofá Módulo Izquierdo
FAZ Sectional Sofa Left

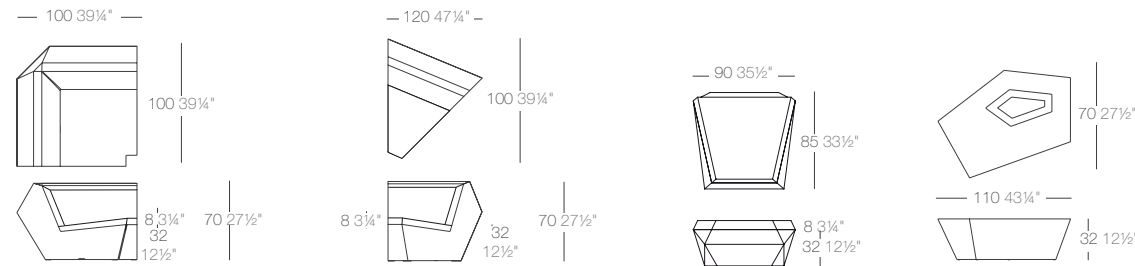

FAZ Sofá Módulo Esquina 90°
FAZ Sectional Sofa Corner 90°

FAZ Sofá Módulo Esquina 45°
FAZ Sectional Sofa Corner 45°

FAZ Chaiselongue
FAZ Ottoman

FAZ Mesa Sofá
FAZ Coffee Table

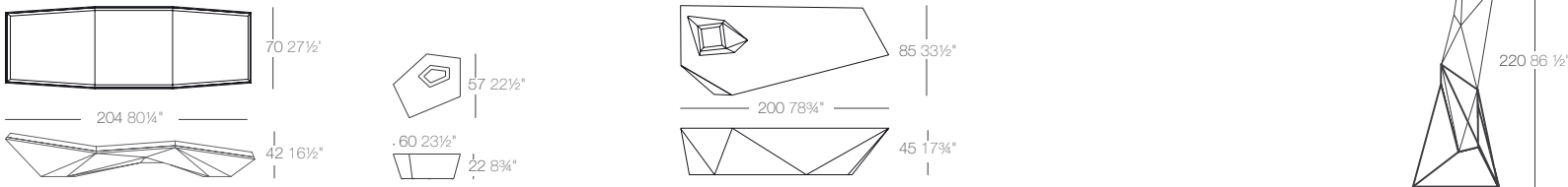

FAZ Tumbona
FAZ Sun Chaise

FAZ Mesa Tumbona
FAZ Table Sun Chaise

FAZ Banco
FAZ Bench

FAZ Lámpara
FAZ Lamp

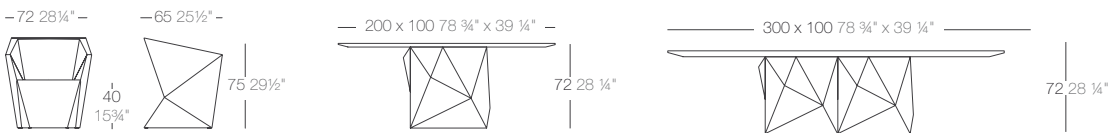

FAZ Sillón
FAZ Armchair

FAZ Mesa 200
FAZ Table 200

FAZ Mesa 300
FAZ Table 300

FAZ COLLECTION by Ramon Esteve



FAZ Silla Inox Ref: 54044
FAZ Chair Stainless

FAZ Silla con brazos Inox Ref: 54045
FAZ Armchair Stainless



FAZ Silla Ref: 54062
FAZ Chair

FAZ Silla con brazos Ref: 54063
FAZ Armchair

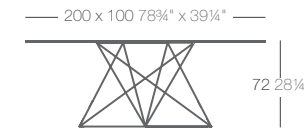

FAZ Mesa Pie Metálico
FAZ Table Lacquered Stainless Base

TABLE LACQUERED STAINLESS BASE	Basic/HPL	Table 200 Mesa 200	Table 300 Mesa 300
Table Stainless Mesa Pie Metálico	54053	Basic/HPL 54016'	54017'
Table Stainless 70x70x72 cm	54058C	Lacquered/HPL 54016F'	54017F'
Table Stainless 80x80x72 cm	54106C	Light/HPL 54016W'	54017W'
Table Stainless 90x90x72 cm	54054C	RGB Led/HPL 54016L'	54017L'
Table Stainless 100x100x72 cm	54060C	Basic/Solid Surface 54016B'	54017B'
		Lacquered/Solid Surface 54016FB'	54017FB'
		White Led/Solid Surface 54016WB'	54017WB'
		RGB Led/Solid Surface 54016LB'	54017LB'
		Basic/Glass 54016G'	54017G'
		Lacquered/Glass 54016FG'	54017FG'
		White Led/Glass 54016WG'	54017WG'
		RGB Led/Glass 54016LG'	54017LG'

FAZ PLANTERS XL

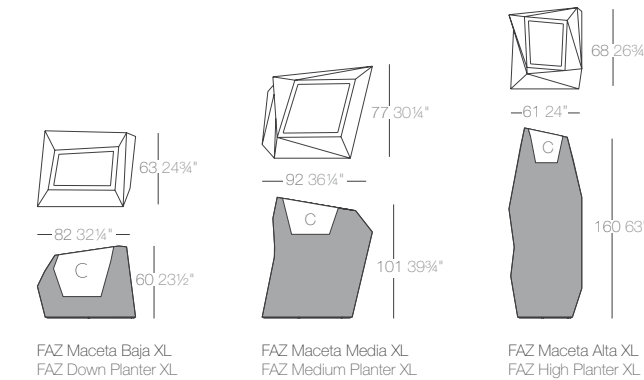

FAZ Maceta Baja XL
FAZ Down Planter XL

FAZ Maceta Media XL
FAZ Medium Planter XL

FAZ Maceta Alta XL
FAZ High Planter XL

FAZ PLANTERS

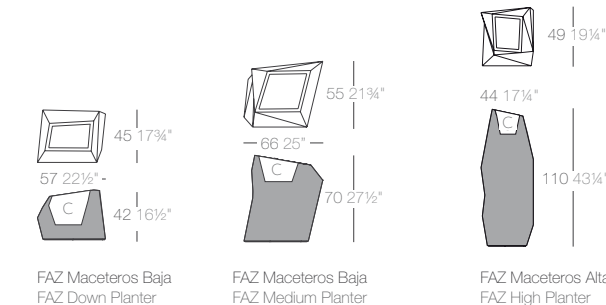

FAZ Maceteros Baja
FAZ Down Planter

FAZ Maceteros Media
FAZ Medium Planter

FAZ Maceteros Alta
FAZ High Planter

	Lounge Chair Butaca	Sofa Right M. Dch	Sofa Armsless M. Central	Sofa Left M. Izq	Corner 90° M. Esquina 90°	Corner 45° M. Esquina 45°	Ottoman Chaise	Coffee Table Mesa sofá	Sun Chaise Tumbona	T. Sun Chaise M.Tumbona	Armchair Sillón	Bench Banco	Lamp Lámpara
Basic	54001* ^t	54003* ^{te}	54004* ^{te}	54002* ^{te}	53005* ^{te}	53010* ^{te}	53006* ^t	53007	54008*	54009 ^f	54015 ^s	54046	-
Self-Watering	-	-	-	-	-	-	-	-	-	-	-	54046R	-
Lacquered	54001F* ^t	54003F* ^{te}	54004F* ^{te}	54002F* ^{te}	53005F* ^{te}	53010F* ^{te}	53006F* ^t	53007F ^t	54008F*	54009F ^t	54015F ^t	54046F	-
Light	54001W* ^{ti}	54003W* ^{tei}	54004W* ^{tei}	54002W* ^{tei}	53005W* ^{tei}	53010W* ^{tei}	53006W* ^{ti}	53007W ^{ti}	54008W* ^{ti}	54009W ^{ti}	54015W ^{ti}	54046W	54018W ^f
RGB Led	54001L* ^{ti}	54003L* ^{tei}	54004L* ^{tei}	54002L* ^{tei}	53005L* ^{tei}	53010L* ^{tei}	53006L* ^{ti}	53007L ^{ti}	54008L* ^{ti}	54009L ^{ti}	54015L ^{ti}	54046L	54018L ^f
RGB Led DMX	54001D* ^{ti}	54003D* ^{tei}	54004D* ^{tei}	54002D* ^{tei}	53005D* ^{tei}	53010D* ^{tei}	53006D* ^{ti}	53007D ^{ti}	54008D* ^{ti}	54009D ^{ti}	54015D ^{ti}	54046D	54018D ^f
Cushion Acolchado	-	-	-	-	-	-	-	-	-	-	54015CO	54046CO	-
Kit Union Kit Assembly	-	-	-	-	-	-	-	-	-	-	54046X	-	-

	L Gal	C (d x d') x h cm in	Basic	Self-Watering	Lacquered	Light	RGB Led	RGB Led DMX	Kit 4 Wheels Ruedas
Down Planter XL Macetero XL Baja	27 7	(30 x 46) x 32 (11¾" x 18") x 12½"	54011A	54011R	54011F	54011W ^{bi}	54011L ^{bi}	54011D ^b	53026
Medium Planter XL Maceteros XL Media	50 13	(40 x 41) x 40 (15¾" x 16¼") x 15¾"	54012A	54012R	54012F	54012W ^{bi}	54012L ^{bi}	54012D ^b	53026
High Planter XL Maceteros XL Alta	29 7 ½	(37 x 27) x 40 (14½" x 10¾") x 15¾"	54013A	54013R	54013F	54013W ^{bi}	54013L ^{bi}	54013D ^b	53026
Down Planter Macetero Baja	10 2 ½	(27,5 x 22) x 27 (10¾" x 8¾") x 10¾"	54020A	54020R	54020F	54020W ^{bi}	54020L ^{bi}	54020D ^b	53026
Medium Planter Macetero Media	21 5 ½	(31 x 30) x 31 (12¼" x 11¾") x 12¼"	54021A	54021R	54021F	54021W ^{bi}	54021L ^{bi}	54021D ^b	53026
High Planter Macetero Alta	10 2 ½	(28 x 21,5) x 27 (11" x 8½") x 10¾"	54022A	54022R	54022F	54022W ^{bi}	54022L ^{bi}	54022D ^b	53026

Thick Cushion: 8 cm / 4" Grosor Acollchado: 8 cm
Thick Cushion Armchair: 4 cm / 1 ½" Grosor Acollchado Sillón: 4 cm

*_ cushions are included in the prize.
*_ acolchados incluidos en el precio.
L_ non-slipping feet included.
L_ incluye tacos antideslizantes.
e_ joint set in order to fix them together.
e_ incluye un set de ensamblaje para fijarlos entre ellos.
L_ possibility of transparent cable & switch for indoor.
L_ posibilidad de cable transparente e interruptor para interior.

VELA COLLECTION

by Ramon Esteve

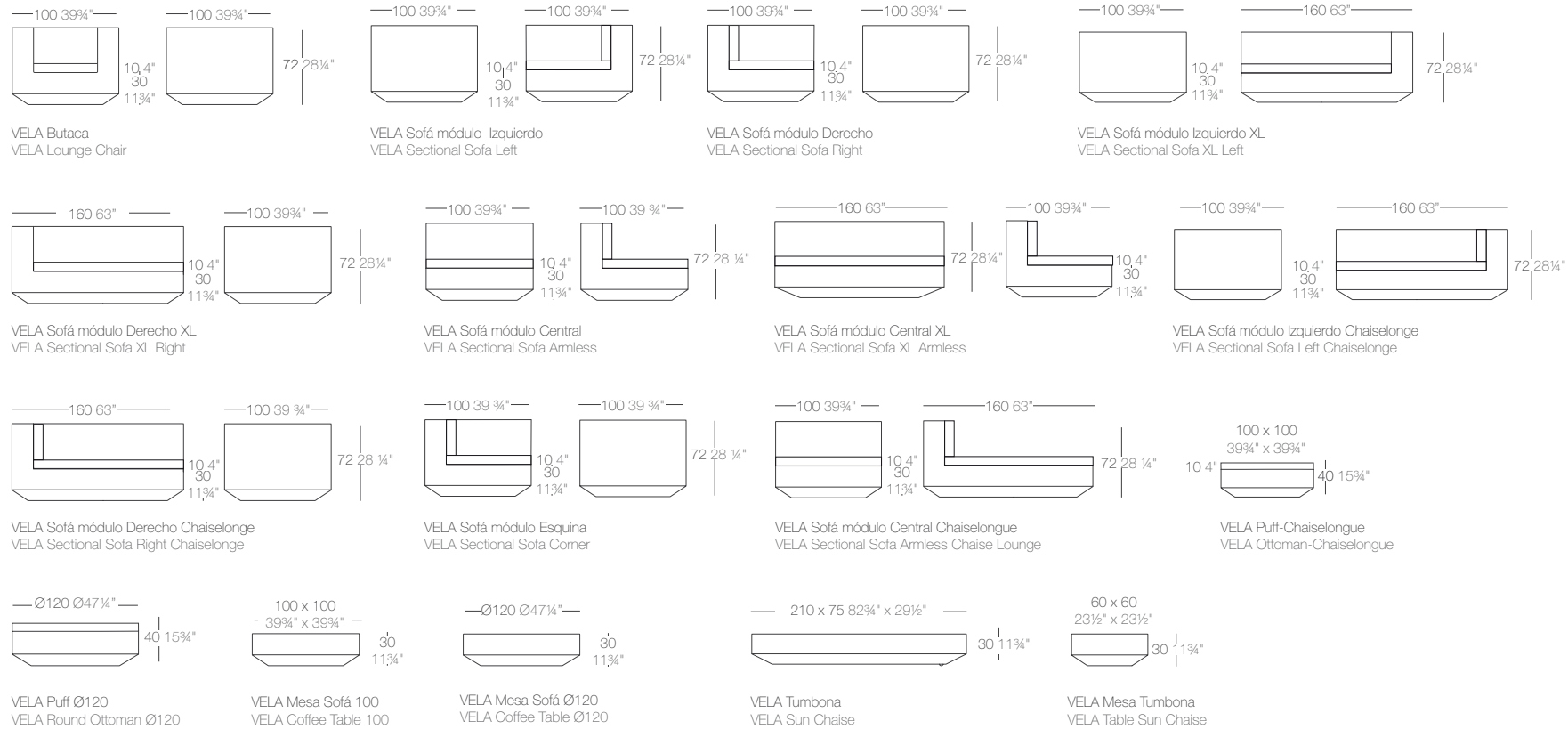

	Lounge Chair Butaca	Sofa Left M. Izq	Sofa Right M. Dch	Sofa XL Left M. Izq XL	Sofa XL Right M. Dch XL	Armless M. Central	XL Armless M. Central XL	Left Chaiselonge M. Izq Chaiselonge	Right Chaiselonge M. Dch Chaiselonge
Basic	54023* ^t	54077* ^t	54078* ^t	54024* ^{te}	54025* ^{te}	54026* ^{te}	54027* ^{te}	54079* ^{te}	54080* ^{te}
Lacquered	54023F* ^t	54077F* ^t	54078F* ^t	54024F* ^{te}	54025F* ^{te}	54026F* ^{te}	54027F* ^{te}	54079F* ^{te}	54080F* ^{te}
Light	54023W* ^{ti}	54077W* ^{ti}	54078W* ^{ti}	54024W* ^{tei}	54025W* ^{tei}	54026W* ^{tei}	54027W* ^{tei}	54079W* ^{tei}	54080W* ^{tei}
RGB Led	54023L* ^{ti}	54077L* ^{ti}	54078L* ^{ti}	54024L* ^{tei}	54025L* ^{tei}	54026L* ^{tei}	54027L* ^{tei}	54079L* ^{tei}	54080L* ^{tei}
RGB Led DMX	54023D* ^{ti}	54077D* ^{ti}	54078D* ^{ti}	54024D* ^{tei}	54025D* ^{tei}	54026D* ^{tei}	54027D* ^{tei}	54079D* ^{tei}	54080D* ^{tei}

	Corner Unit M. Esquina	Armless Chaise M. Central Chaise	Otto.Chaiselonge Puff Chaiselongue	Ottoman Ø120 Puff Ø120	Coffee Table 100 Mesa sofá 100	Table sofa Ø120 Mesa sofá Ø120	Sun Chaise Tumbona	Table Sun Chaise Mesa Tumbona
Basic	54029* ^{te}	54028* ^{te}	54032* ^{te}	54033* ^t	54030 ⁱ	54031 ⁱ	54034* ^{am}	54047 ⁱ
Lacquered	54029F* ^{te}	54028F* ^{te}	54032F* ^{te}	54033F* ^t	54030F ⁱ	54031F ⁱ	54034F* ^{am}	54047F ⁱ
Light	54029W* ^{tei}	54028W* ^{tei}	54032W* ^{tei}	54033W* ^{ti}	54030W ^{ti}	54031W ^{ti}	54034W* ^{ami}	54047W ^{ti}
RGB Led	54029L* ^{tei}	54028L* ^{tei}	54032L* ^{tei}	54033L* ^{ti}	54030L ^{ti}	54031L ^{ti}	54034L* ^{ami}	54047L ^{ti}
RGB Led DMX	54029D* ^{tei}	54028D* ^{tei}	54032D* ^{tei}	54033D* ^{ti}	54030D ^{ti}	54031D ^{ti}	54034D* ^{ami}	54047D ^{ti}
Top Polyethylene Cubre Polietileno	-	-	-	-	54030C	54031C	-	54047C
Glass Top Cubre Glass	-	-	-	-	54030P	54031P	-	54047P

Thick Cushion: 10 cm / 4" Grosor Acolchado: 10 cm
Thick Cushion Chair: 4 cm / 1½" Grosor Acolchado Silla: 4 cm

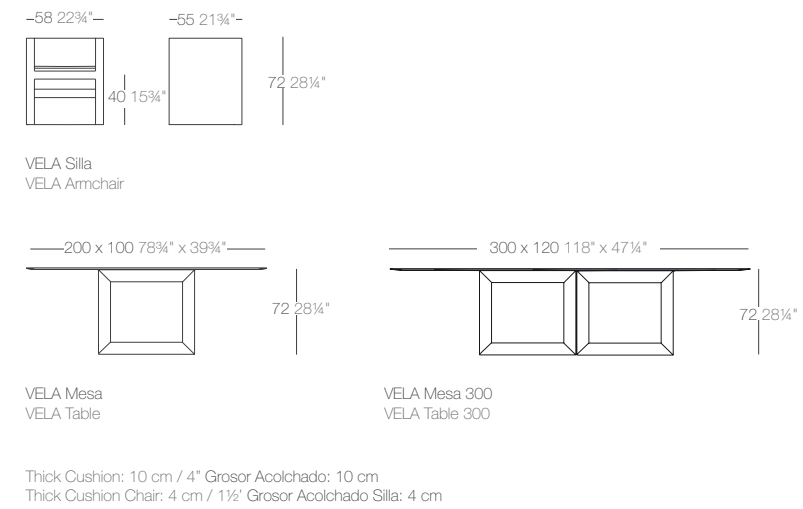

VELA BARRA

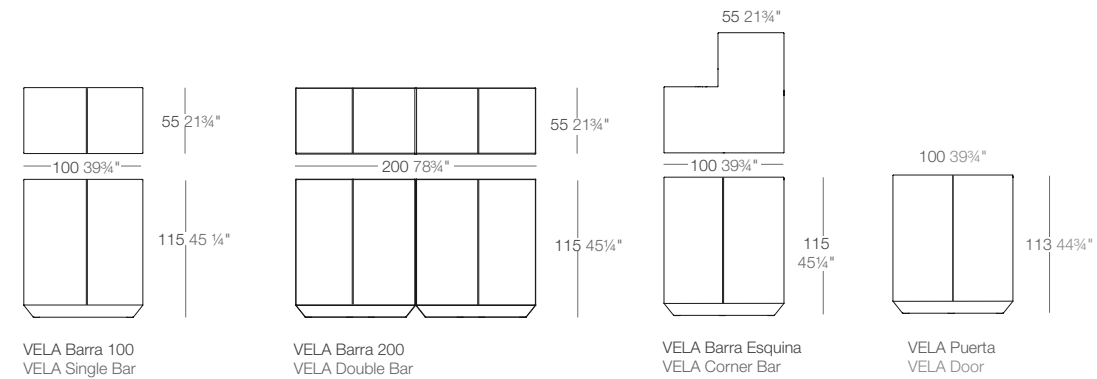

	Basic	Lacquered	Light	RGB Led	RGB Led DMX	SET 2 Shelves SET 2 Estantes	Inox Top Cubre Inox	Glass Top Cubre Glass	Set 8 Wheels SET 8 Ruedas	Pack Sound Bluetooth System	Pack Battery + Charger Pack Batería + Cargador
Single Bar Barra 100	54081	54081F	54081W	54081L ⁱ	54081D	54081E	54081X	54081C	54081B	54099	54100
Double Bar Barra 200	54082	54082F	54082W	54082L ⁱ	54082D	54082E	54082X	54082C	54081B	54099	54100
Corner Bar Barra Esquina	54083	54083F	54083W	54083L ⁱ	54083D	54083E	54083X	54083C	54081B	54099	54100
Door Puerta	54084	54084F	-	-	-	-	-	-	-	-	-

*_ cushions are included in the prize.

L_ non-slipping feet included.

e_ joint set in order to fix them together.

L_ possibility of transparent cable & switch for indoor.

*_ acolchados incluidos en el precio.

L_ incluye tacos antideslizantes.

e_ incluye un set de ensamblaje para fijarlos entre ellos.

L_ posibilidad de cable transparente e interruptor para interior.

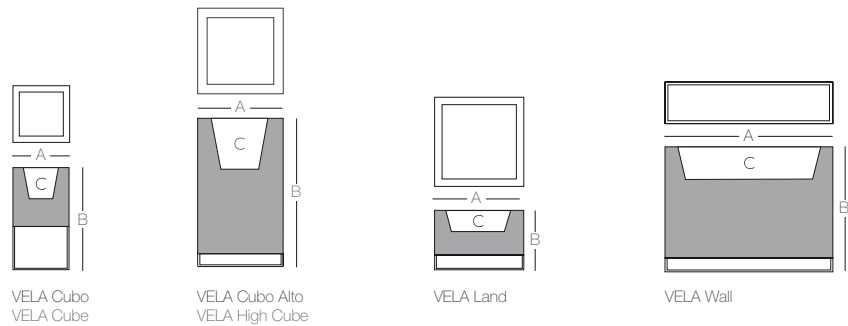

	A cm in	x	B cm in	L Gal	C (d x d') x h cm in	Basic	Self-Watering	Lacquered	Light	RGB Led	RGB Led DMX				
Cubo 40 Cubo 40	40 x 40	15 3/4" x 15 3/4"	x	70	27 1/2"	22	6	(31 x 31) x 31	(12 1/2" x 12 1/2") x 12 1/2"	54035A	54035R	54035F	54035W ^b	54035L ^b	54035D ^b
Cubo 40 Cubo 60	60 x 60	23 1/2" x 23 1/2"	x	100	39 1/4"	72	19	(46 x 46) x 46	(18" x 18") x 18"	54042A	54042R	54042F	54042W ^b	54042L ^b	54042D ^b
High Cube 40 Cubo Alto 40	40 x 40	15 3/4" x 15 3/4"	x	90	35 1/2"	24	6 1/2	(30 x 30) x 33	(11 3/4" x 11 3/4") x 13"	54049A	54049R	54049F	54049W ^b	54049L ^b	54049D ^b
High Cube 60 Cubo Alto 60	60 x 60	23 1/2" x 23 1/2"	x	100	39 1/4"	72	19	(46 x 46) x 46	(18" x 18") x 18"	54036A	54036R	54036F	54036W ^b	54036L ^b	54036D ^b
Land	60 x 60	23 1/2" x 23 1/2"	x	40	15 3/4"	30	8	(46 x 46) x 24	(18" x 18") x 9 1/2"	54037A	54037R	54037F	54037W ^b	54037L ^b	54037D ^b
Wall	30 x 120	11 3/4" x 47 1/4"	x	90	35 1/2"	60	16	(24 x 114) x 24	(9 1/2" x 45") x 9 1/2"	54038A	54038R	54038F	54038W ^b	54038L ^b	54038D ^b

	A cm in	x	B cm in	L Gal	C (d x d') x h cm in	Nano	Nano Lacquered	Nano Led				
Nano Cube 28 Nano Cubo 28	18 x 18	7" x 7"	x	28	11"	2	1/2	(14 x 14) x 12	(5 1/2" x 5 1/2") x 4 3/4"	54043A	54043F	54043W
Nano Cube 36 Nano Cubo 36	18 x 18	7" x 7"	x	36	14 1/4"	2	1/2	(14 x 14) x 12	(5 1/2" x 5 1/2") x 4 3/4"	54039A	54039F	54039W
Nano High Cube 28 Nano Cubo Alto	18 x 18	7" x 7"	x	46	18"	1,5	1/2	(14 x 14) x 23	(5 1/2" x 5 1/2") x 9"	54040A	54040F	54040W

VELA MACETEROS

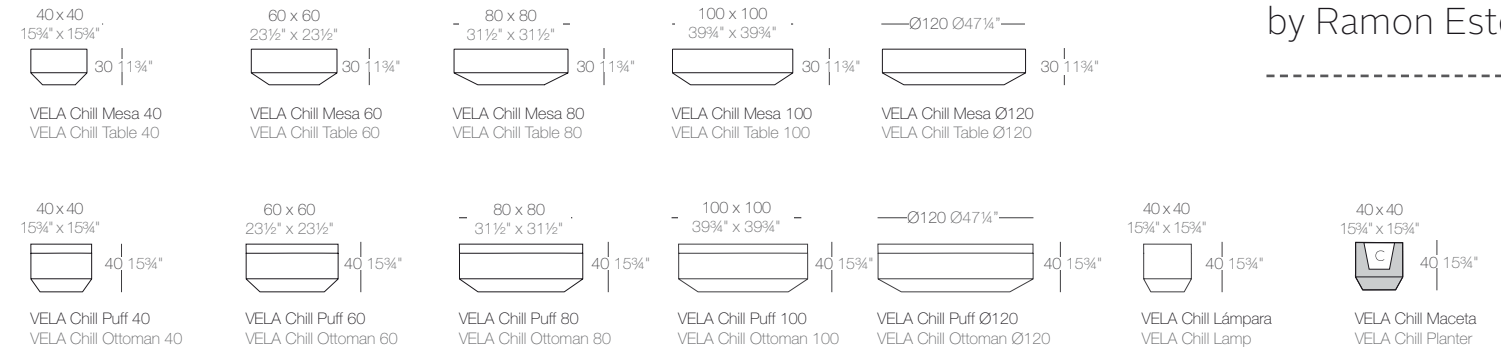

	L Gal	C (d x d') x h cm in	Basic	Self-Watering	Lacquered	Light	RGB Led	RGB Led DMX	Top Cubre Glass	Top Cubre PE	
Table 40 Mesa 40	-	-	54041 ^{to}	-	54041F ^{to}	54041W ^{to}	54041L ^{to}	54041D ^{to}	54041C	54041P	
Table 60 Mesa 60	-	-	54047 ^{to}	-	54047F ^{to}	54047W ^{to}	54047L ^{to}	54047D ^{to}	54047C	54047P	
Table 80 Mesa 80	-	-	54048 ^{to}	-	54048F ^{to}	54048W ^{to}	54048L ^{to}	54048D ^{to}	54048C	54048P	
Table 100 Mesa 100	-	-	54030 ^{to}	-	54030F ^{to}	54030W ^{to}	54030L ^{to}	54030D ^{to}	54030C	54030P	
Table Ø120 Mesa Ø120	-	-	54031 ^{to}	-	54031F ^{to}	54031W ^{to}	54031L ^{to}	54031D ^{to}	54031C	54031P	
Planter Maceta	19	5	(31 x 31) x 27 (12 1/4" x 12 1/4") x 10 3/4"	54073A (Planter)	54073R	54073F	54073W ^b	54073L ^b	54073D ^b	-	-
Puff 40 Puff 40	-	-	54069 ^{to}	-	54069F ^{to}	54069W ^{to}	54069L ^{to}	54069D ^{to}	-	-	
Puff 60 Puff 60	-	-	54070 ^{to}	-	54070F ^{to}	54070W ^{to}	54070L ^{to}	54070D ^{to}	-	-	
Puff 80 Puff 80	-	-	54071 ^{to}	-	54071F ^{to}	54071W ^{to}	54071L ^{to}	54071D ^{to}	-	-	
Puff 100 Puff 100	-	-	54032 ^{to}	-	54032F ^{to}	54032W ^{to}	54032L ^{to}	54032D ^{to}	-	-	
Puff Ø120 Puff Ø120	-	-	54033 ^{to}	-	54033F ^{to}	54033W ^{to}	54033L ^{to}	54033D ^{to}	-	-	
Lamp Lámpara	-	-	-	-	-	54072W ^{to}	54072L ^{to}	54072D ^{to}	-	-	

Thick Cushion: 10 cm / 4" Grosor Acolchado: 10 cm

VELA LÁMPARAS

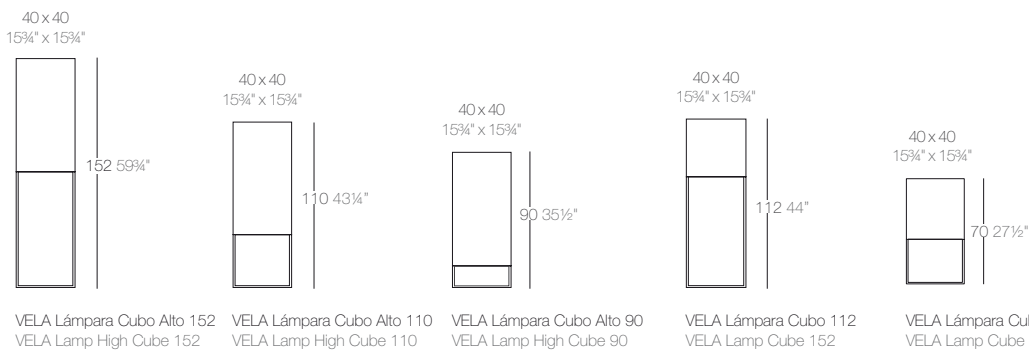

	Light	RGB Led	RGB Led DMX
Lamp High Cube 152 Lámpara Cubo Alto 152	54068W	54068L ^b	54068D ^b
Lamp High Cube 110 Lámpara Cubo Alto 110	54067W	54067L ^b	54067D ^b
Lamp High Cube 90 Lámpara Cubo Alto 90	54066W	54066L ^b	54066D ^b
Lamp Cube 112 Lámpara Cubo 112	54065W	54065L ^b	54065D ^b
Lamp Cube 70 Lámpara Cubo 70	54064W	54064L ^b	54064D ^b

b_ self-watering included.

*_ cushions are included in the prize

t_ non-slipping feet included

e_ join set in order to fix them together

l_ possibility of transparent cable & switch for indoor

b_ incluye sistema de autorriego

*_ acolchados incluidos en el precio

t_ incluye tacos antideslizantes

e_ incluye un set de ensamblaje para fijarlos entre ellos

l_ posibilidad de cable transparente e interruptor para interior

VELA CHILL COLLECTION by Ramon Esteve

VELA BARRA CATERING

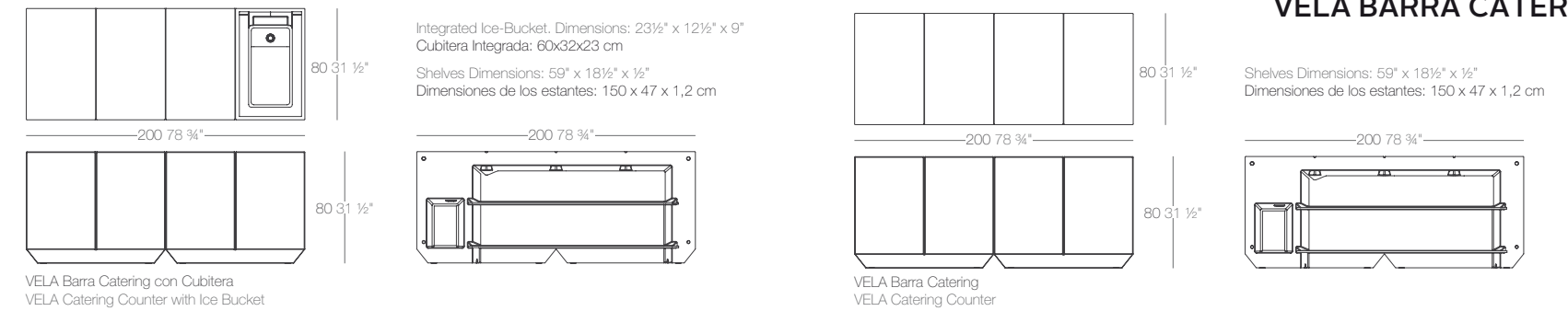

VELA Barra Catering con Cubitera
VELA Catering Counter with Ice Bucket

VELA Barra Catering
VELA Catering Counter

	Basic	Lacquered	Light	RGB Led	SET 2 Shelves SET 2 Estantes	Inox Top Cubre Inox	Glass Top Cubre Glass	Set 8 Wheels SET 8 Ruedas	Pack Sound Bluetooth System	Pack Battery + Charger Pack Batería + Cargador
Bar Counter with Ice Bucket Barra Catering con Cubitera	54109	54109F	54109W	54109L ^b	54109E	54109X	54109C	56001B	54099	54100
Bar Counter Barra Catering	54103	54103F	54103W	54103L ^b	54103E	54103X	54103C	56001B	54099	54100

DIMENSIONS DIMENSIONES

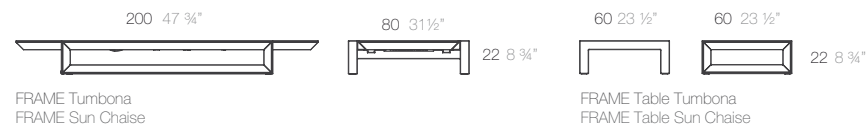
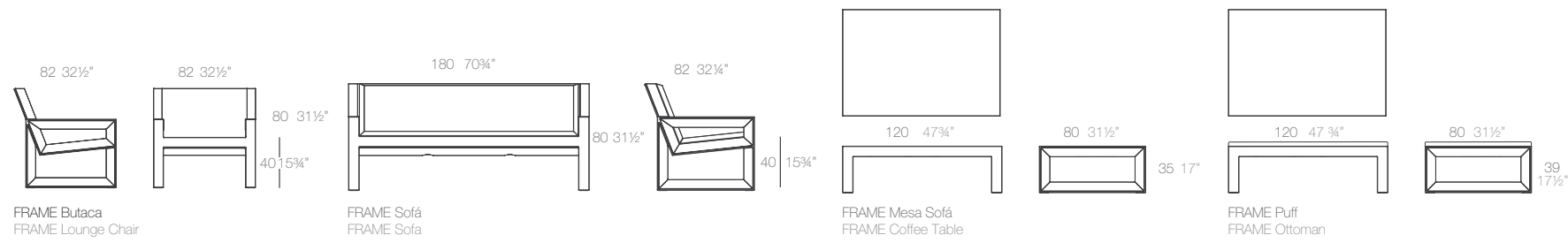

FRAME COLLECTION by Ramon Esteve

	Basic	Lacquered	Cushion Acolchado
Longue chair Butaca	54088	54088F	54088CO
Sofa Sofá	54095	54095F	54095CO
Coffee Table Mesa Sofá	54089	54089F	-
Ottoman Puff	54102	54102F	-
Table 100 Mesa 100	54090	54090F	-
Table 200 Mesa 200	54091	54091F	-
Armchair Sillón	54094	54094F	54094CO
Chair Silla	54093	54093F	54093CO
Stool Taburete bajo	54096	54096F	54096CO
Bench Banco	54087	54087F	54087CO
Sun Chaise Tumbona	54097	54097F	54097CO
Table Sun Chaise Mesa Tumbona	54092	54092F	-
Table 50 Mesa 50	54075	54075F	-
Bar Stool Taburete	54076	54076F	54076CO

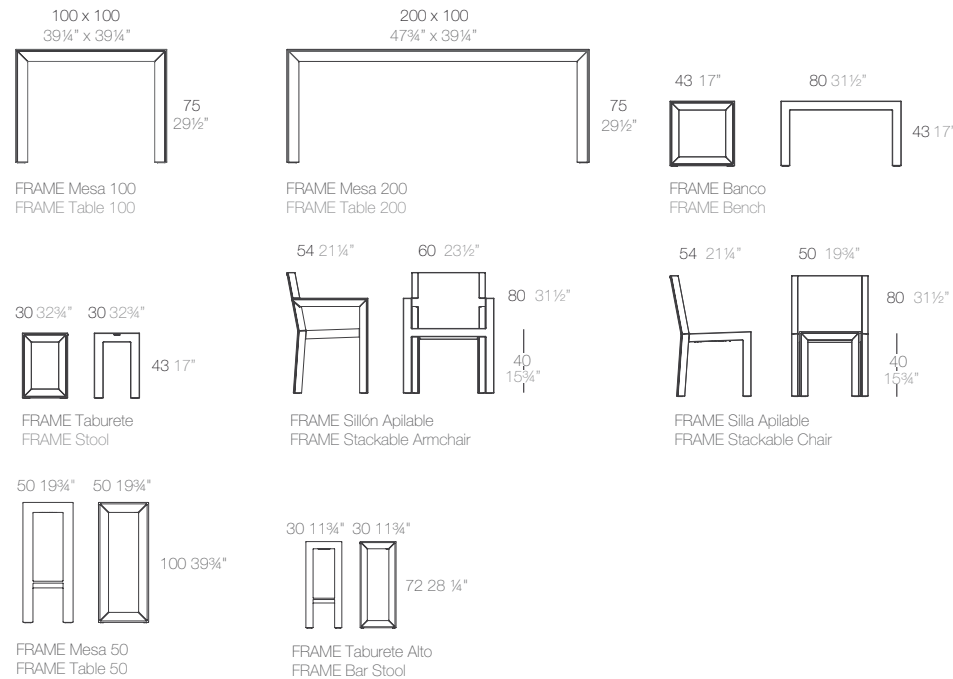

STONE COLLECTION by Stefano Giovannoni

	Basic	Lac- quered	Light	RGB Led	RGB Led DMX	Cushion Acolchado	Top Cubre
Sofa Sofá	55005	55005F	55005W ^{bi}	55005L ^{bi}	55005D ^b	55005CO	-
Lounge Chair Poltrona	55006	55006F	55006W ^{bi}	55006L ^{bi}	55006D ^b	55006CO	-
Table Mesa	55007	55007F	55007W ^{bi}	55007L ^{bi}	55007D ^b	-	55007C

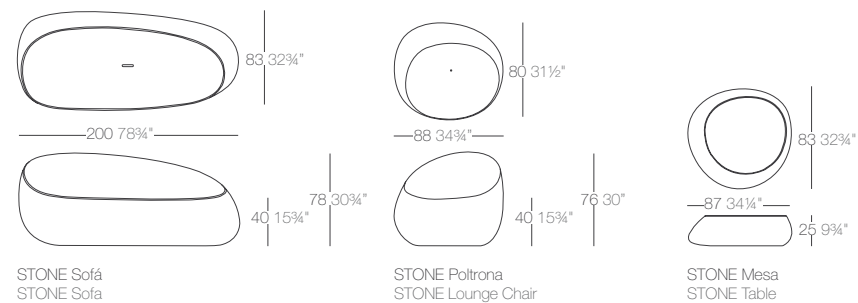

STONE COLLECTION

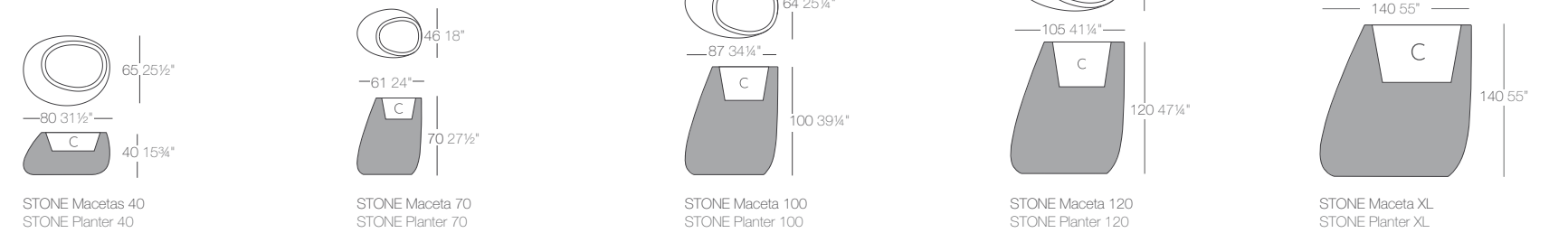

	L Gal	C (d x d') x h cm in	Basic	Self-Watering	Lacquered	Light	RGB Led	RGB Led DMX
Planter 40 Maceta 40	32 8 ½	(52 x 39) x 26 (20½" x 15¼") x 10¼"	55008A	55008R	55008F	55008W ^{bi}	55008L ^{bi}	55008D ^b
Planter 70 Maceta 70	20 5 ½	(37 x 29) x 28 (14½" x 11½") x 10¼"	55009A	55009R	55009F	55009W ^{bi}	55009L ^{bi}	55009D ^b
Planter 100 Maceta 100	52 13 ½	(54 x 44) x 39 (21¼" x 15¼") x 15¼"	55010A	55010R	55010F	55010W ^{bi}	55010L ^{bi}	55010D ^b
Planter 120 Maceta 120	105 27 ½	(65 x 56) x 46 (25½" x 22") x 18"	55011A	55011R	55011F	55011W ^{bi}	55011L ^{bi}	55011D ^b
Planter XL Maceta XL	252 66 ½	(90 x 72) x 62 (35½" x 28¼") x 24½"	55012A	55012R	55012F	55012W ^{bi}	55012L ^{bi}	55012D ^b

b_ self-watering included.
 i_ possibility of transparent cable & switch for indoor.
 b_ incluye sistema de autorriego.
 i_ posibilidad de cable transparente e interruptor para interior.

PILLOW COLLECTION by Stefano Giovannoni

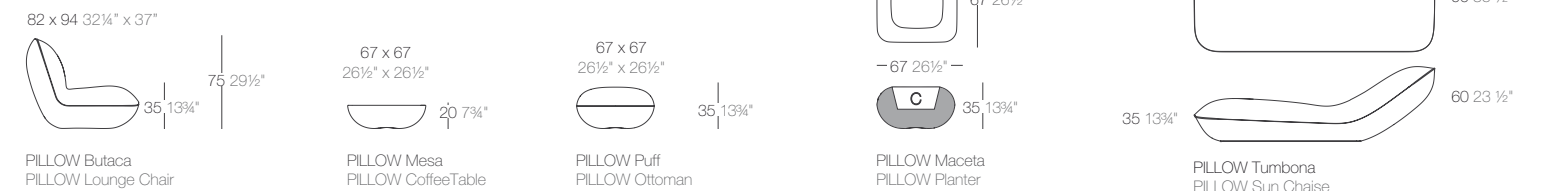

	L Gal	C (d x h) cm in	Basic	Self-Watering	Lacquered	Light	RGB Led	RGB Led DMX
Lounge Chair Butaca	-	-	55001	-	55001F	55001W ⁱ	55001L ⁱ	55001D
Coffee Table Mesa	-	-	55002	-	55002F	55002W ⁱ	55002L ⁱ	55002D
Ottoman Puff	-	-	55003	-	55003F	55003W ⁱ	55003L ⁱ	55003D
Planter Maceta	24 6½	21 x 24 8¼" x 9½"	55004	55004R	55004F	54020W ^{bi}	55004L ^b	55004D ^b
Sun Chaise Tumbona	-	-	55013	-	55013F	55013W ⁱ	55013L ⁱ	55013D

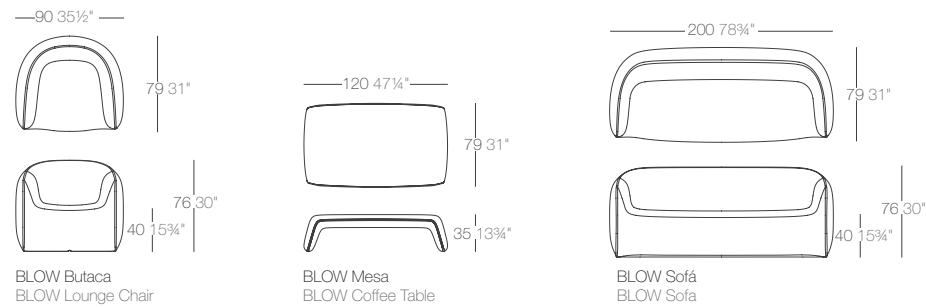

BLOW Butaca
BLOW Lounge Chair

BLOW Mesa
BLOW Coffee Table

BLOW Sofá
BLOW Sofa

	Basic	Lacquered	Light	RGB Led	Cushion Acolchado	Table Top Cubre Mesa
Armchair Butaca	55014	55014F	55014W ⁱ	55014L ⁱ	55014CO	-
Table Mesa	55015	55015F	55015W ⁱ	55015L ⁱ	-	55015CO
Sofa Sofá	55016	55016F	54016W ⁱ	55016L ⁱ	55016CO	-

ⁱ posibilidad de cable transparente e interruptor para interior.
ⁱ possibility of transparent cable & switch for indoor.

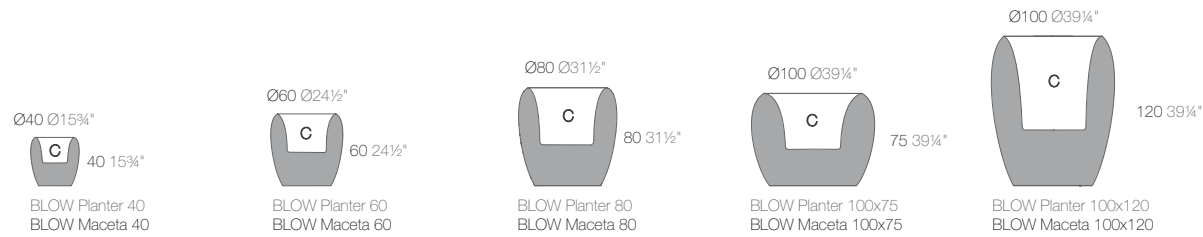

BLOW Planter 40
BLOW Maceta 40

BLOW Planter 60
BLOW Maceta 60

BLOW Planter 80
BLOW Maceta 80

BLOW Planter 100x75
BLOW Maceta 100x75

BLOW Planter 100x120
BLOW Maceta 100x120

	L Gal	C (d x d') x h cm in	Basic	Self-Watering	Lacquered	Light	RGB Led	Led DMX
Planter Maceta Ø40	10 2,64	Ø32 x 21 Ø12½" x 8¼"	55017A	55017R	55017F	55017W ^{bi}	55017L ^{bi}	55017D ^{bi}
Planter Maceta Ø60	28 7,4	Ø48 x 32 Ø19" x 12½"	55018A	55018R	55018F	55018W ^{bi}	55018L ^{bi}	55018D ^{bi}
Planter Maceta Ø80	68 18	Ø64 x 46 Ø25¼" x 18"	55019A	55019R	55019F	55019W ^{bi}	55019L ^{bi}	55019D ^{bi}
Planter Maceta Ø100x75	135 35,7	Ø80 x 46 Ø31½" x 18"	55020A	55020R	55020F	55020W ^{bi}	55020L ^{bi}	55020D ^{bi}
Planter Maceta Ø100x120	104 28,3	Ø78 x 55 Ø30¾" x 21¾"	55021A	55021R	55021F	55021W ^{bi}	55021L ^{bi}	55021D ^{bi}

^b incluye sistema de autorriego self-watering included.
ⁱ posibilidad de cable transparente e interruptor para interior. possibility of transparent cable & switch for indoor.

VASES COLLECTION by JMFerrero

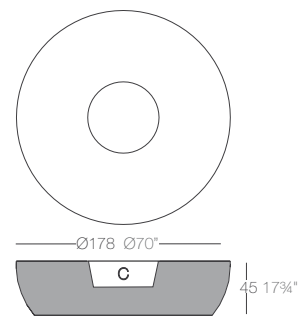

VASES Isla
VASES Island

	L Gal	C (d x h) cm in	Basic	Self-Watering	Lacquered	Light	RGB Led	Cushion Acolchado
Island Isla	103 271/4	Ø69 x 39 Ø27¼" x 15¼"	47178A	47178R	47178F	47178W ^{bi}	47178L ^{bi}	44578CO

Thick Cushion Isla: 4 cm / 1 ½' Grosor Acolchado Isla: 4 cm

^b incluye sistema de autorriego self-watering included.
ⁱ posibilidad de cable transparente e interruptor para interior. possibility of transparent cable & switch for indoor.

VASES COLLECTION by JMFerrero

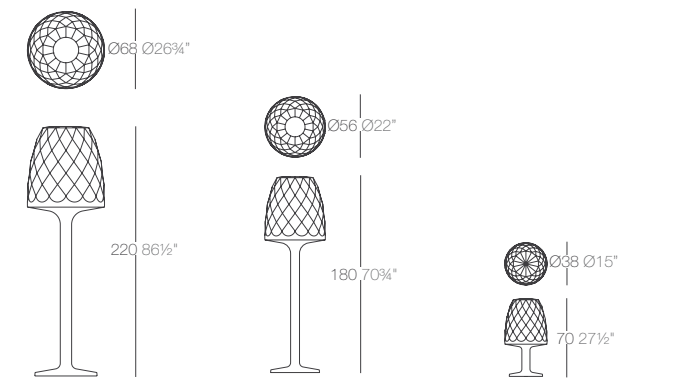

VASES Lámpara de pie 220
VASES High Lamp 220

VASES Lámpara de pie 180
VASES Medium Lamp 180

VASES Lámpara de pie 70
VASES Down Lamp 70

	Light	RGB Led
High Lamp 220 Lámpara de pie 220	47068W ⁱ	47068L ⁱ
Medium Lamp 180 Lámpara de pie 180	47056W ⁱ	47056L ⁱ
Down Lamp 70 Lámpara de pie 70	47038W ⁱ	47038L ⁱ



VASES Lamp
VASES Bola lámpara

A cm in	Kit Ceiling Holder Colgante	Light	RGB Led
Ø30 Ø11¾"	48000X	48030W ⁱ	48030L ⁱ
Ø40 Ø15¾"	48000X	48040W ⁱ	48030L ⁱ
Ø60 Ø24¾"	48000X	48060W ⁱ	48030L ⁱ

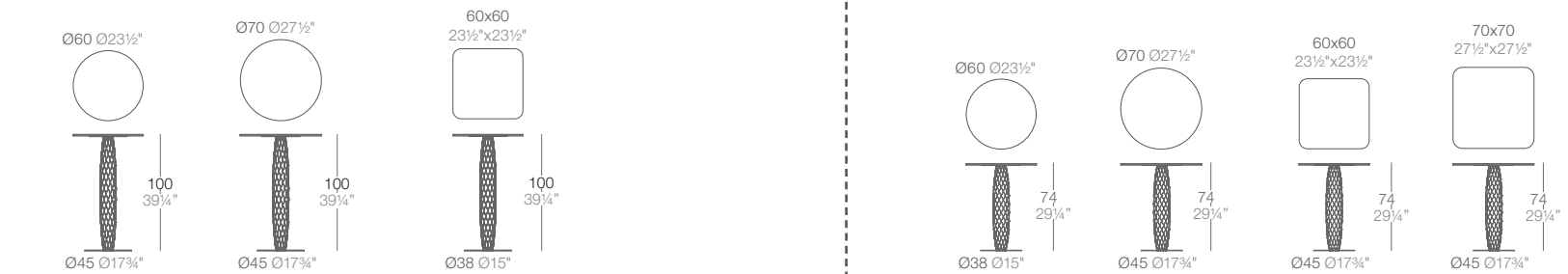

VASES Mesa Alta Redonda
VASES Round Bar Table

VASES Mesa Alta Cuadrada
VASES Square Bar Table

VASES Mesa Redonda
VASES Round Table

VASES Mesa Cuadrada
VASES Square Table

	Basic	Lacquered
Round Bar Table Ø23½" Mesa Alta Redonda Ø60	47072	47072F
Round Bar Table Ø27½" Mesa Alta Redonda Ø70	47078	47078F
Square Bar Table 23½" Mesa Alta Cuadrada 60	47072C	47072CF

ⁱ posibilidad de cable transparente e interruptor para interior.
ⁱ possibility of transparent cable & switch for indoor.

VASES COLLECTION by JMFerrero

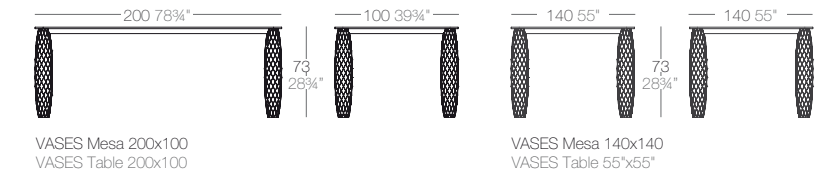

VASES Mesa 200x100
VASES Table 200x100

VASES Mesa 140x140
VASES Table 55"x55"

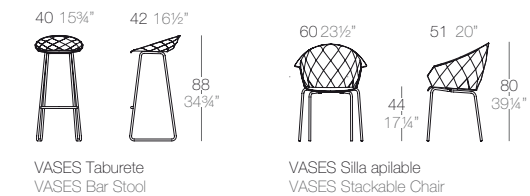

VASES Taburete
VASES Bar Stool

VASES Silla apilable
VASES Stackable Chair

	Basic	Lacquered
Stackable Chair Silla Apilable	47070	-
Bar Stool Taburete	47071	-
Table 200x100 Mesa 200x100	47079	47079F
Table 100x100 Mesa 100x100	47080	47080F

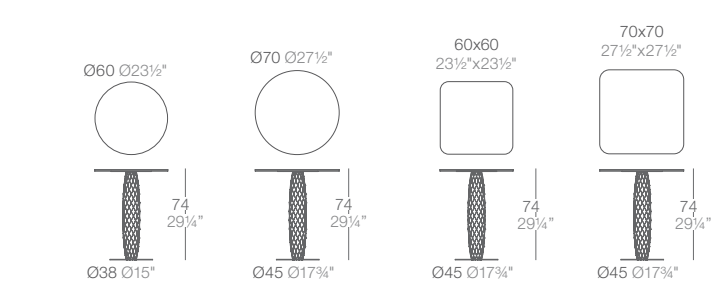

VASES Mesa Redonda
VASES Round Table

VASES Mesa Cuadrada
VASES Square Table

	Basic	Lacquered
Round Table Ø23½" Mesa Redonda Ø60	47073	47073F
Round Table Ø27½" Mesa Redonda Ø70	47074	47074F
Square Table 23½" Mesa Cuadrada 60	47073C	47073CF
Square Table 27½" Mesa Cuadrada 70	47074C	47074CF

ⁱ posibilidad de cable transparente e interruptor para interior.
ⁱ possibility of transparent cable & switch for indoor.

VASES COLLECTION by JMFerrero

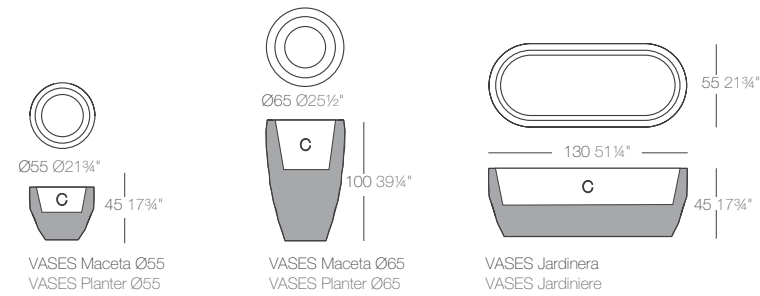

	L Gal	C (d x d') x h cm in	Basic	Self-Watering	Lacquered	Light	RGB Led
Maceta Ø55	41 11	Ø46 x 30 Ø18" x 11¼"	47055A	47055R	47055F	47055W ^b	47055L ^b
Maceta Ø65	56 15	Ø50 x 39 Ø19¼" x 15¼"	47065A	47065R	47065F	47065W ^b	47065L ^b
Jardinera Jardiniere	128 34	(120 x 46) x 39 (47¼" x 18") x 15¼"	47130A	47130R	47130F	47130W ^b	47130L ^b

b_ incluye sistema de autorriego self-watering included.
 L_ posibilidad de cable transparente e interruptor para interior. possibility of transparent cable & switch for indoor.

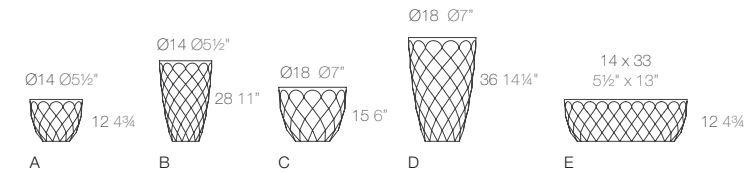

	NANO PlanterS	L Gal	C (d x d') x h cm in	Nano	Nano Lacquered	Nano Led
A	Nano Vases Ø14 x 12	0,5 1/4	Ø11 x 8 Ø4¼" x 3¼"	47012A	47012F	47012W
B	Nano Vases Ø14 x 28	1 1/2	Ø11 x 15 Ø4¼" x 6"	47028A	47028F	47028W
C	Nano Vases Ø18 x 15	1 1/2	Ø14 x 11 Ø5½" x 4¼"	47018A	47018F	47018W
D	Nano Vases Ø18 x 36	2 1/2	Ø18 x 18 Ø7" x 7"	47036A	47036F	47036W
E	Nano Jardiniere Nano Jardinera	2,5 3/4	(11 x 31) x 9 (4¼" x 12¼") x 3½"	47033A	47033F	47033W

KES COLLECTION by Buratti + Battiston Architects

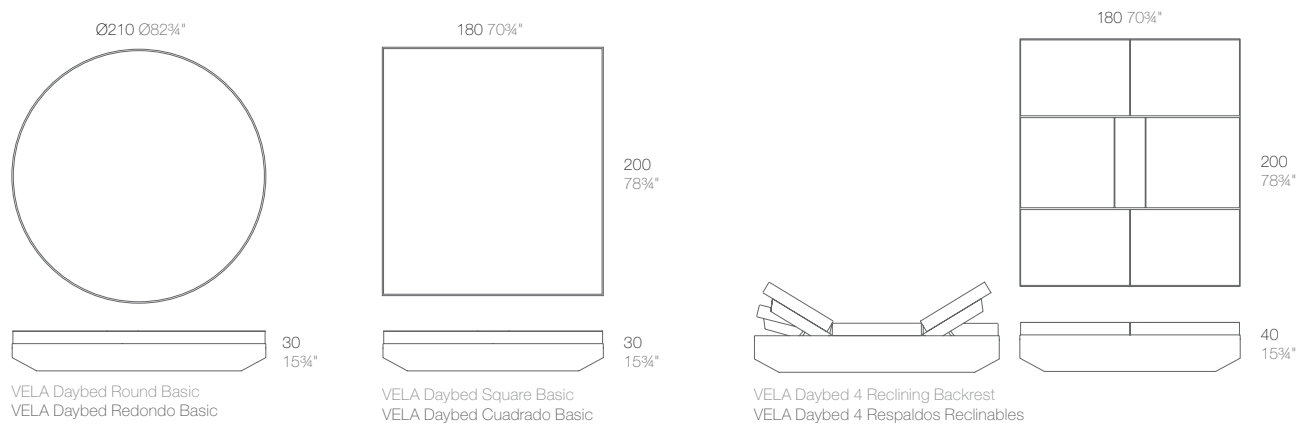
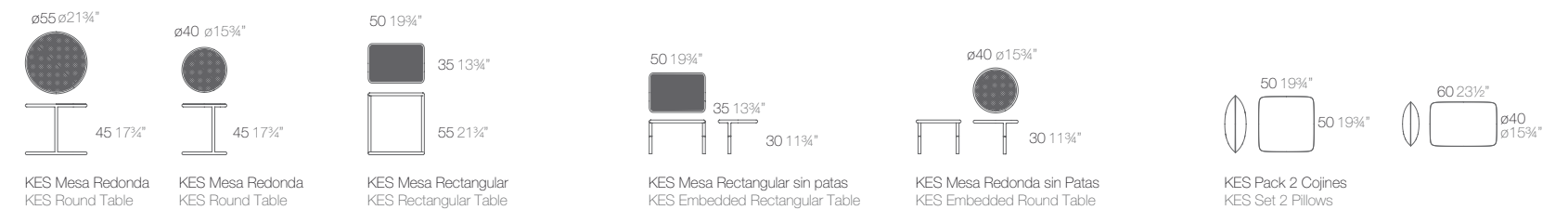
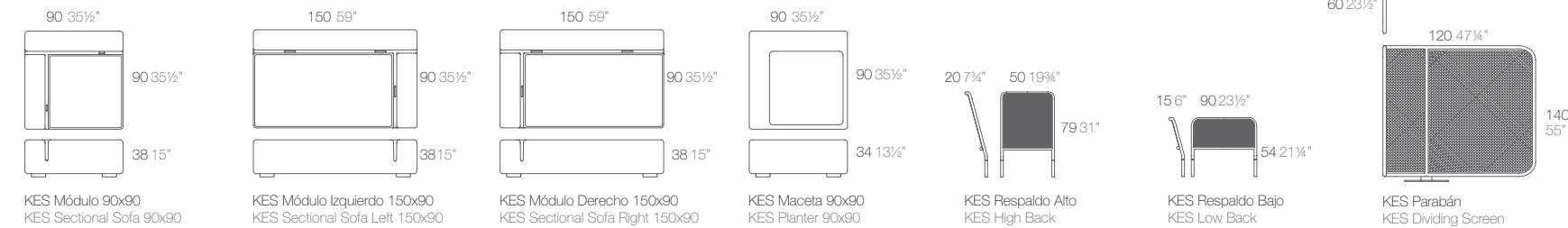

VELA DAYBED by Ramón Esteve

	Round Daybed	Square Daybed	Daybed 4 Reclining Backrest	Daybed 2 Reclining Backrest	Daybed
Basic	54108	54107	54104	54105	54104
Lacquered	54108F	54107F	54104F	54105F	54104F
Light	54108W	54107W	54104W	54105W	54104W
RGB Led	54108L	54107L	54104L	54105L	54104L
RGB Led DMX	54108D	54107D	54104D	54105D	54104D

Extras	Ref
Pack Outdoor Bluetooth Sound System	54099
Pack Bateria + Cargador Pack Battery + Charger	54100
Pack 4 Cojines 60x60 cm 4 Pillows Pack 60 x 60 cm	54101

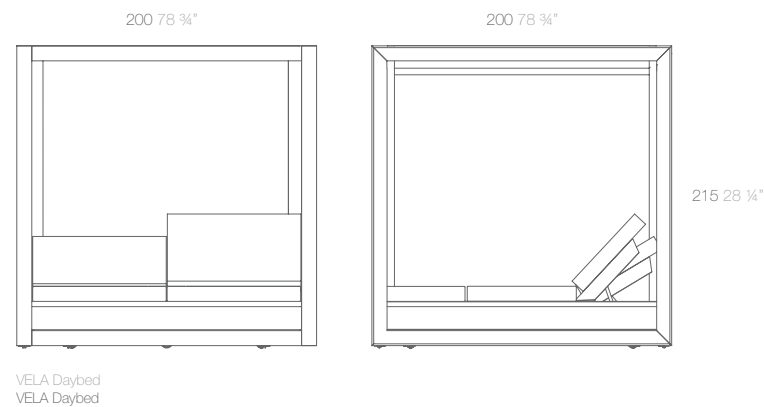

	Basic	Lacquered	Light	RGB Led	RGB Led DMX
Sec. Sofa 90 Módulo 90	64001	64001F	64001W	64001L	64001D
Sec. Sofa Left 90 M. Izquierdo 150x90	64002	64002F	64002W	64002L	64002D
Sec. Sofa Right 90 M. Derecho 150x90	64003	64003F	64003W	64003L	64003D
Planter Maceta	64004	64004F	64004W	64004L	64004D
High Back Respaldo Alto	64005	-	-	-	-
Low Back Respaldo Bajo	64006	-	-	-	-
L Parabán	60004	-	-	-	-
Round Table 55 Mesa Redonda 55	64008	-	-	-	-
Round Table 40 Mesa Redonda 40	64007	-	-	-	-
Rectangular Table 55 Mesa Rectangular55	64009	-	-	-	-
Round Table 40 Legs Mesa Redonda 40 con patas	64010	-	-	-	-
Rectangular Table Legs Mesa Rectangular con patas	64011	-	-	-	-
Set 2 Pillows Pack 2 Cojines	64014	-	-	-	-

	L Gal	C (d x d') x h cm in	Basic	Self-Watering	Lacquered	Light	RGB Led	RGB Led DMX
Planter Maceta	70 18,5	62,5 x 62,5 x 18 24½" x 24½" x 7"	64004	64004R	64004F	64004W	64004L	64004D



	A cm in	x	B cm in	L Gal	Basic	Lacquered	Light	RGB Led
Flask 65	Ø36 Ø14¼"	x	65 25½"	5 1½	49036A	49036F	49036W	49036L ⁱ
Flask 100	Ø55 Ø21¾"	x	100 39¼"	5 1½	49055A	49055F	49055W	49055L ⁱ



	A cm in	x	B cm in	L Gal	Basic	Lacquered	Light	RGB Led
Erlenmeyer 65	Ø36 Ø14¼"	x	65 25½"	1,5 1/2	49058A	49058F	49058W	49058L ⁱ
Erlenmeyer 100	Ø55 Ø21¾"	x	100 39¼"	4 1	49059A	49059F	49059W	49059L ⁱ

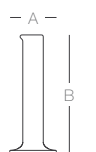

	A cm in	x	B cm in	L Gal	Basic	Lacquered	Light	RGB Led
Pipe 65	Ø30 Ø11¼"	x	65 25½"	1,5 1/2	49056A	49056F	49056W	49056L ⁱ
Pipe 100	Ø40 Ø15¾"	x	100 39¼"	3,5 1	49057A	49057F	49057W	49057L ⁱ

CHEMISTUBES COLLECTION

by Teresa Sapey

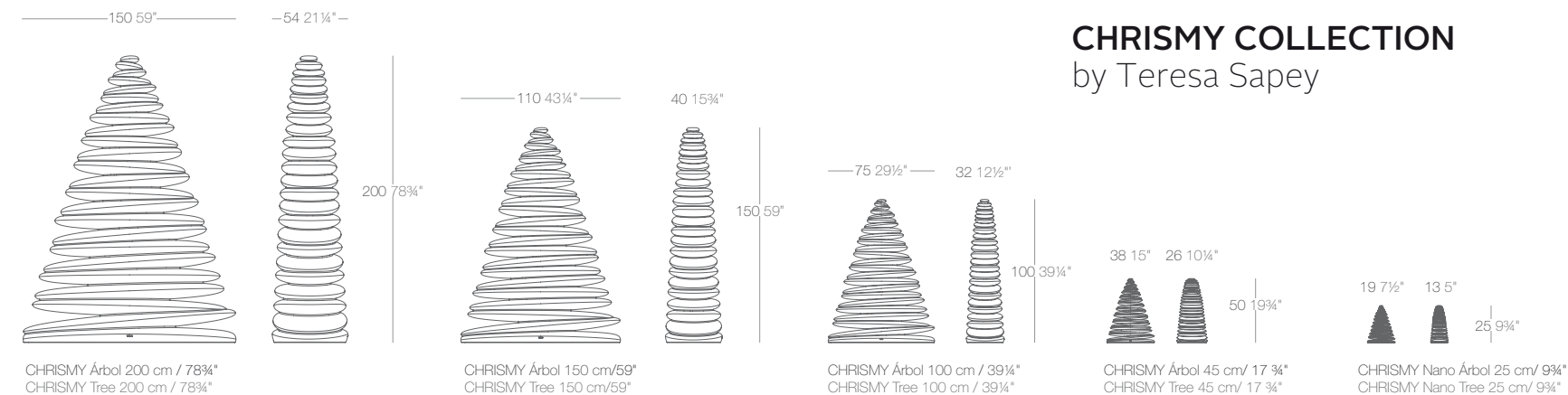

	Warm Led Led Cálido	RGB Led	RGB Led	RGB Led With Battery RGB Led Con Batería	Base Inox
Tree 200 cm/78¾" Árbol 200 cm/78¾"	49072W	49072L ⁱ	49072D ⁱ	-	49072X
Tree 150 cm/59" Árbol 150 cm/59"	49071W	49071L ⁱ	49071D ⁱ	-	49071X
Tree 100 cm/39¼" Árbol 100 cm/39¼"	49073W	49073L ⁱ	49073D ⁱ	-	49073X
Tree 45 cm/17¾" Árbol 45 cm/17¾"	49070W	49070L ⁱ	49070D ⁱ	-	-
Nano Tree 25 cm/9¾" Nano Árbol 25 cm/9¾"	49069W	49069L	49069D	49069Y	-

CHRISMY COLLECTION

by Teresa Sapey

i_ possibility of transparent cable & switch for indoor.
i_ posibilidad de cable transparente e interruptor para interior.

ADÁN COLLECTION

by Teresa Sapey

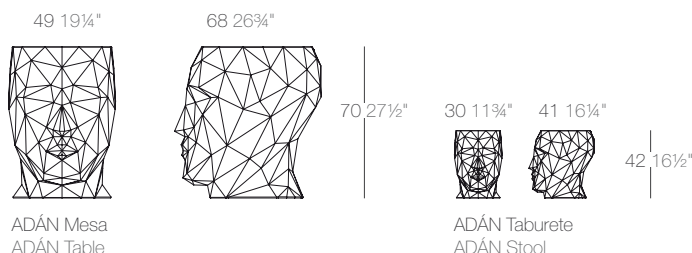

	Basic	Lacquered	Light	RGB Led	RGB Led DMX
Table Mesa	49062	49062F	49062W	49062L ⁱ	49062D ⁱ
Stool Taburete	49066	49066F	49066W	49066L ⁱ	49066D ⁱ

i_ possibility of transparent cable & switch for indoor.
i_ posibilidad de cable transparente e interruptor para interior.

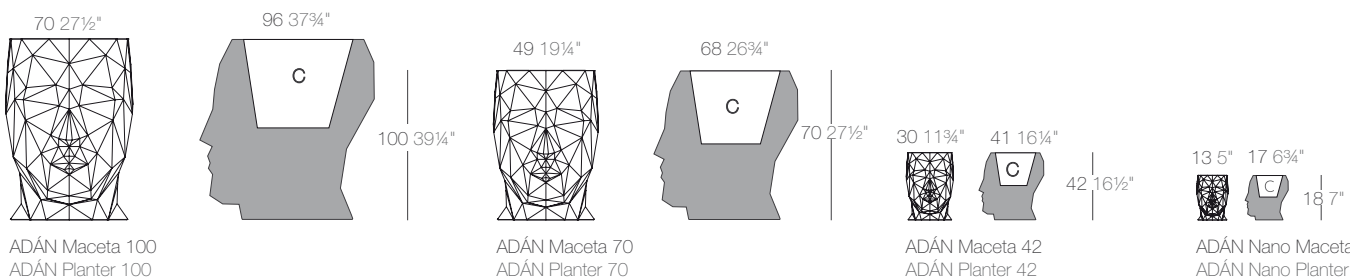

ADÁN Maceta 100
ADÁN Planter 100

ADÁN Maceta 70
ADÁN Planter 70

ADÁN Maceta 42
ADÁN Planter 42

ADÁN Nano Maceta
ADÁN Nano Planter

	L Gal	C (d x d') x h cm in	Basic	Self-Watering	Lacquered	Light	RGB Led	RGB Led DMX
Planter 100 Maceta 100	24 11	(62 x 57) x 46 (24½" x 22½") x 18"	49060A	49060R	49060F	49060W ^b	49060L ^b	49060D ^b
Planter 70 Maceta 70	24 11	(43 x 39) x 28 (17" x 15¼") x 11"	49060A	49060R	49060F	49060W ^b	49060L ^b	49060D ^b
Planter 42 Maceta 42	4,5 1 ¼	(30 x 24) x 14,2 (11¾" x 9½") x 5½"	49064A	49064R	49064F	49064W ^b	49064L ^b	49064D ^b
Nano Planter Nano Maceta	0,5 0,25	(9 x 10) x 10,6 (3½" x 4") x 4¼"	49068A	-	49068F	49068W	-	-

b_ self-watering included.
i_ possibility of transparent cable & switch for indoor.
b_ incluye sistema de autorriego.
i_ posibilidad de cable transparente e interruptor para interior.

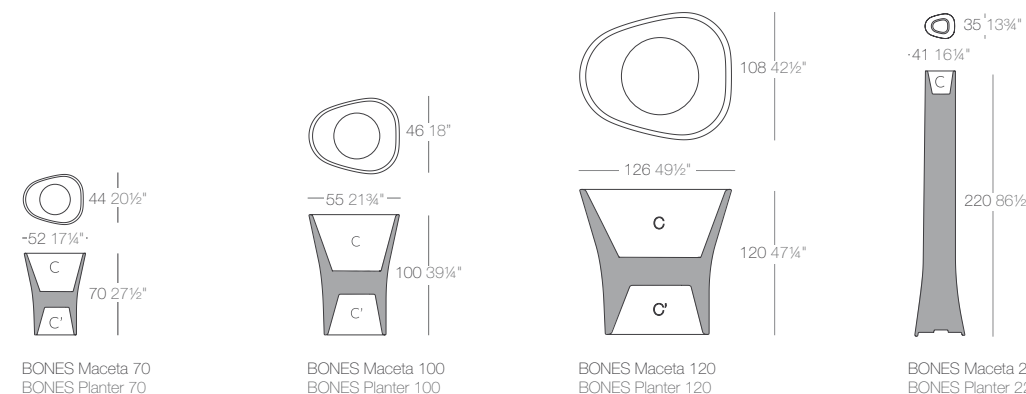

BONES Maceta 70
BONES Planter 70

BONES Maceta 100
BONES Planter 100

BONES Maceta 120
BONES Planter 120

BONES Maceta 220
BONES Planter 220

	L Gal	L' Gal	C (d x h) cm in	C' (d x h) cm in	Basic	Self-Watering	Lacquered	Light	RGB Led	RGB Led DMX
Planter 70 Maceta 70	29 7¾	10 2¾	(47 x 38) x 28 (19¾" x 15") x 11"	(31 x 25) x 20 (12½" x 9¾") x 9¾"	57002A	57002R	57002F	57002W ^b	57002L ^b	57002D ^b
Planter 100 Maceta 100	30,5 8	14 3¾	(50 x 39) x 28 (19¾" x 15¼") x 11"	(31 x 24) x 28 (12½" x 9½") x 11"	57003A	57003R	57003F	57003W ^b	57003L ^b	57003D ^b
Planter 120 Maceta 120	452 119	143 37¾	(126 x 104) x 63 (49½" x 41") x 24¾"	(86 x 71) x 46 (33¾" x 27½") x 18"	57004A	57004R	57004F	57004W ^b	57004L ^b	57004D ^b
Planter 220 Maceta 220	4 1	-	(21 x 17) x 19 Ø6¾" x 7½"	-	57001A	-	57001F	57001W ^b	57001L ^b	57001D ^b

BONES COLLECTION

by Ludovica+Roberto Palomba

b_ self-watering included.
i_ possibility of transparent cable & switch for indoor.
b_ incluye sistema de autorriego.
i_ posibilidad de cable transparente e interruptor para interior.

BYE-BYE COLLECTION

by Harry&Camila

	L Gal	C (d x h) cm	Basic	Self-Watering	Lacquered	Light	RGB Led
Planter 70 Maceta 70	10 2¾	Ø18 x 24 Ø7" x 9½"	58003A	58003R	58003F	58003W ^{b1}	58003L ^{b1}
Planter 100 Maceta 100	15 4	Ø25 x 30 Ø9¾" x 11¾"	58004A	58004R	58004F	58004W ^{b1}	58004L ^{b1}

b_ self-watering included.
 L_ possibility of transparent cable & switch for indoor.
 b_ incluye sistema de autorriego.
 L_ posibilidad de cable transparente e interruptor para interior.

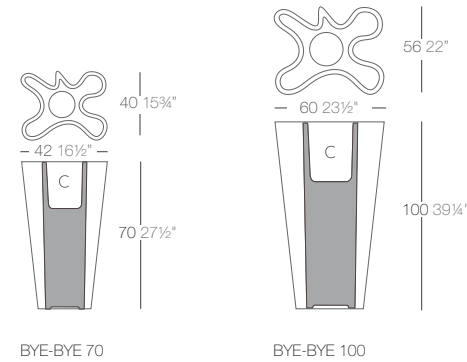

BYE-BYE 70

BYE-BYE 100

AGATHA COLLECTION

by Agatha Ruiz de la Prada

kids

	L Gal	C (d x h) cm	Basic	Lacquered	Light	RGB Led	RGB Led DMX	Two-Tone	Lacquered Two-Tone
Chair Silla	5,6 1½	94 x 90 x 28 37" x 35½" x 11"	52001	52001F	52001W	52001L ⁱ	52001D ⁱ	52001P	52001FP
Table Mesa	-	-	52002	52002F	52002W	52002L ⁱ	52002D ⁱ	52002P	52002FP
Planter Maceta	-	-	52003R	52003F	52003W ^b	52003L ^b	52003D ^b	52003P	52003FP

Pencil Case
 Portalápices

Included with the table. Optional color, except bicolor finished (white color).

Incluido en la mesa. Color opcional, excepto en el acabado bicolor (color blanco).

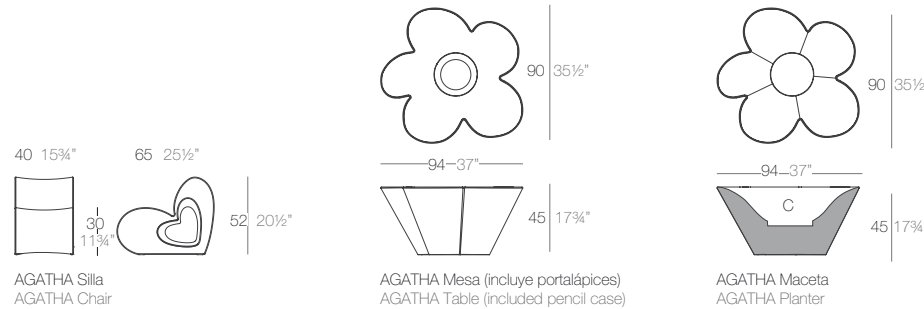

AGATHA Silla
 AGATHA Chair

AGATHA Mesa (incluye portalápices)
 AGATHA Table (included pencil case)

AGATHA Maceta
 AGATHA Planter

Two-Tone Colors Colores Bicolor

- Blanco - Azul White - Blue
- Blanco - Rojo White - Red
- Blanco - Magenta White - Magenta
- Blanco - Amarillo White - Yellow

UFO COLLECTION

by Ora-ïto

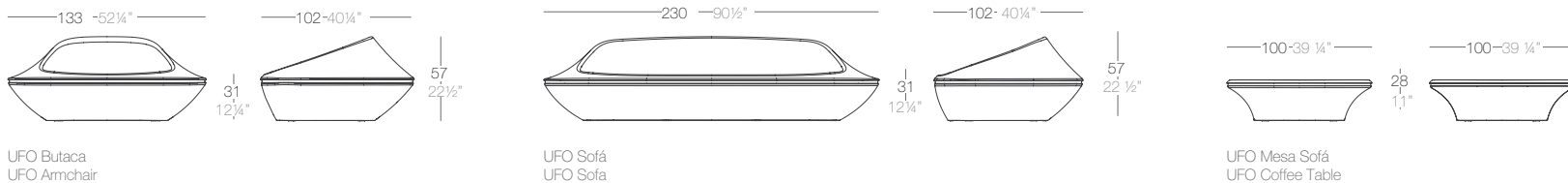

UFO Butaca
 UFO Armchair

UFO Sofá
 UFO Sofa

UFO Mesa Sofá
 UFO Coffee Table

	Basic	Lacquered	Light	RGB Led	RGB Led DMX	Glass Top Cubre Cristal	Set 5 Wheels Set 5 Ruedas
Armchair Butaca	63001	63001F	63001W	63001L ⁱ	63001D	-	63001B
Sofa Sofá	63002	63002F	63002W	63002L ⁱ	63002D	-	-
Coffee Table Mesa Sofá	63003	63003F	63003W	63003L ⁱ	63003D	63003C	-

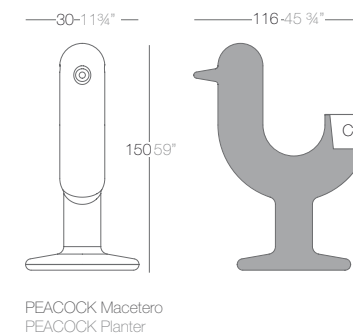

PEACOCK Macetero
 PEACOCK Planter

PEACOCK COLLECTION

by Eero Aarnio

	L Gal	C (d x d') x h cm in	Self-Watering	Lacquered	Light	RGB Led	RGB Led DMX
Peacock Planter	9 2,38	ø24 x 22 ø9½" x 8¾"	61001R	61001F	61001W	61001L ⁱ	61001D

ROULETTE COLLECTION

by Eero Aarnio

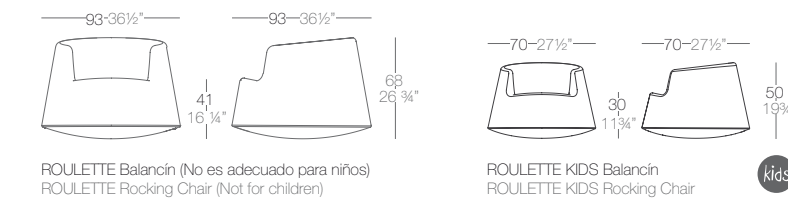

ROULETTE Balancín (No es adecuado para niños)
 ROULETTE Rocking Chair (Not for children)

ROULETTE KIDS Balancín
 ROULETTE KIDS Rocking Chair

kids

	Basic	Lacquered
Roulette	61002	61002F
Roulette Kids	61005	61005F

ROSINANTE COLLECTION

by Eero Aarnio

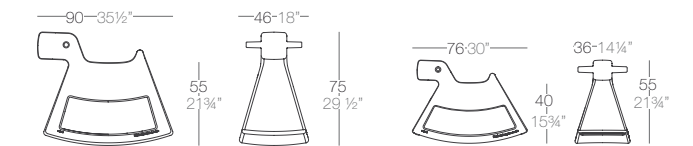

ROSINANTE Balancín (No es adecuado para niños)
 ROSINANTE Rocking Horse (Not for children)

ROSINANTE KIDS Balancín
 ROSINANTE KIDS Rocking Horse

kids

	Basic	Lacquered
Rosinante	61003	61003F
Rosinante Kids	61004	61004F

FIESTA COLLECTION

by Archirivolto Design

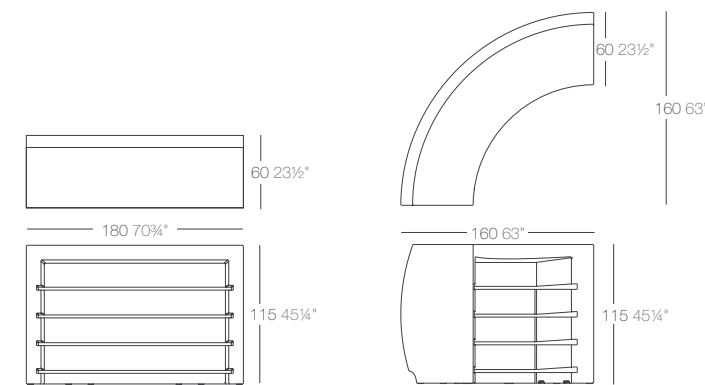

FIESTA Barra
 FIESTA Bar

FIESTA Barra Curva
 FIESTA Curved Bar

	Basic	Lacquered	Light	RGB Led	RGB Led DMX	SET 2 Shelves SET 2 Estantes
Bar Barra	56001	56001F	56001W	56001L ⁱ	56001D	56001E
Curve Bar Barra Curva	56002	56002F	56002W	56002L ⁱ	56002D	56002E

	Inox Top Cubre Inox	Glass Top Cubre Glass	Set 8 Wheels SET 8 Ruedas	Pack Sound Bluetooth System	Pack Battery + Charger Pack Bateria + Cargador
Bar Barra	56001X	56001C	56001B	54099	54100
Curved Bar Barra Curva	56002X	56002C	56001B	54099	54100

b_ self-watering included.
 L_ possibility of transparent cable & switch for indoor.

DIMENSIONS DIMENSIONES

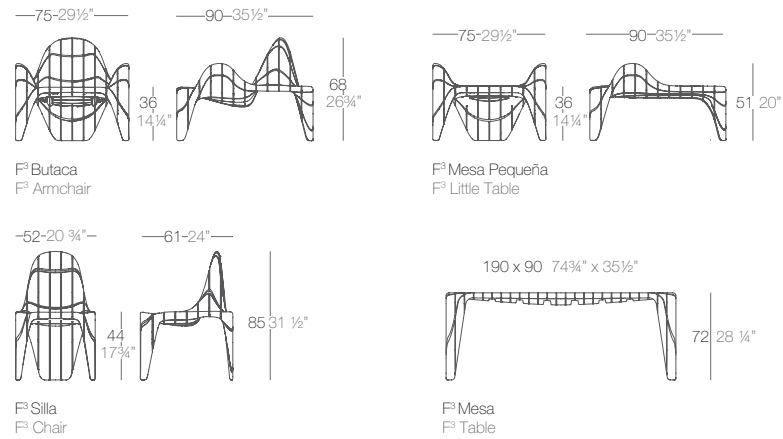

f³ COLLECTION by Fabio Novembre

	Basic	Lacquered	Lacquered Two-Tone	Cushion Acolchado
Armchair Butaca	60001	60001F	60001FP	60001CO
Little Table Mesa Pequeña	60002	60002F	60002FP	-
Sun Chaise Tumbona	60005	60005F	60005FP	60005CO
Chair Silla	60003	60003F	60003FP	60003CO
Table Mesa	60004	60004F	60004FP	-

BIOPHILIA COLLECTION by Ross Lovegrove

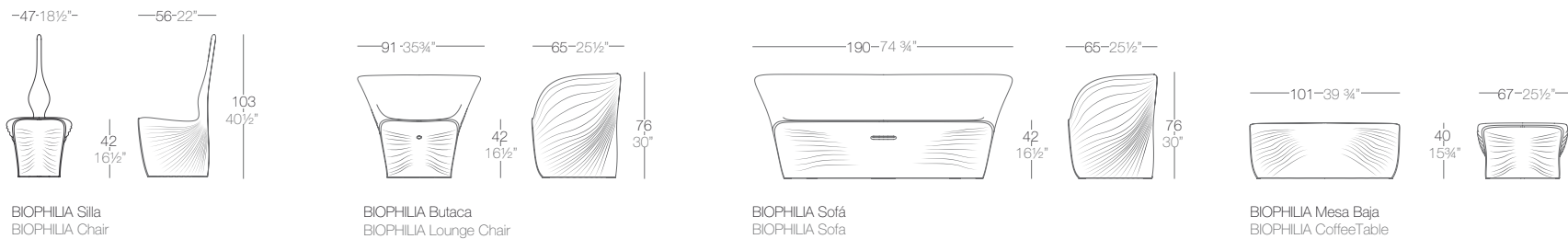

	Basic	Lacquered	Light	RGB Led	RGB Led DMX	Lacquered Two-Tone	Cushion Acolchado
Chair Silla	59001	59001F	59001W	59001L	59001D	59001FP	59001CO
Lounge Chair Butaca	59002	59002F	59002W	59002L	59002D	59002FP	59002CO
Sofa Sofá	59003	59003F	59003W	59003L	59003D	59003FP	59003CO
Coffee Table Mesa	59004	59004F	59004W	59004L	59004D	59004FP	-

b_ self-watering included.
l_ possibility of transparent cable & switch for indoor.

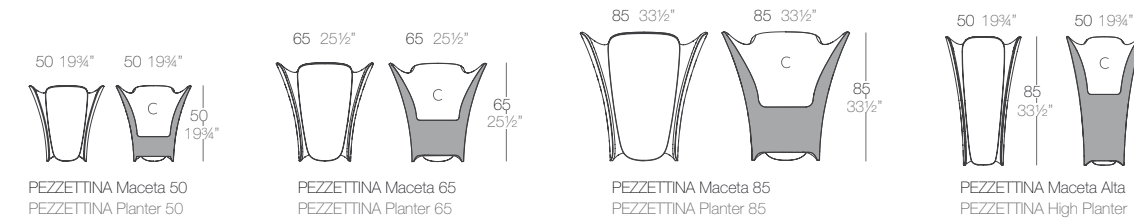

PEZZETTINA COLLECTION by Archirivolto Design

	L Gal	C (d x d") x h cm in	Basic	Self-Watering	Lacquered	Light	RGB Led	RGB Led DMX
Planter 50 Maceta 50	18 4%	(40 x 40) x 29 (15¾" x 15¾") x 11½"	56006A	56006R	56006F	56006W	56006L	56006D
Planter 65 Maceta 65	35 9¼	(53 x 53) x 31 (20¾" x 20¾") x 12¼"	56007A	56007R	56007F	56007W	56007L	56007D
Planter 85 Maceta 85	78 20½	(69 x 69) x 41 (27¼" x 27¼") x 16¼"	56008A	56008R	56008F	56008W	56008L	56008D
High Planter Maceta Alta	20 5¼	(39 x 39) x 32 (15¼" x 15¼") x 12½"	56009A	56009R	56009F	56009W	56009L	56009D

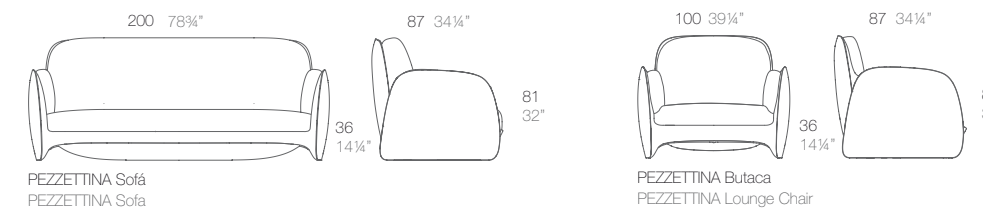
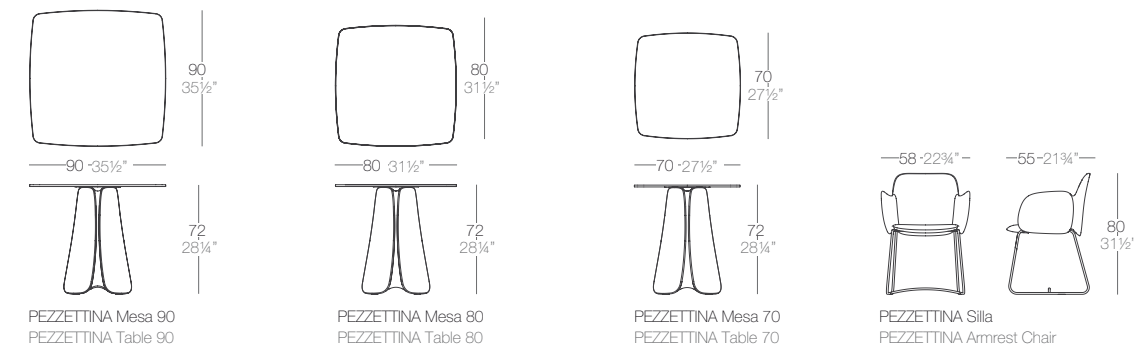

	Basic	Lacquered	Light	RGB Led	Led DMX
Armrest Chair Silla	56005	56005F	-	-	-
Table 90 Mesa 90	56014	56014F	56014W	56014L	56014D
Table 80 Mesa 80	56013	56013F	56013W	56013L	56013D
Table 70 Mesa 70	56012	56012F	56012W	56012L	56012D
Lounge Chair Butaca	56010	56010F	56010W	56010L	56010D
Sofa Sofá	56011	56011F	56011W	56011L	56011D

ACCESSORIES COMPLEMENTOS

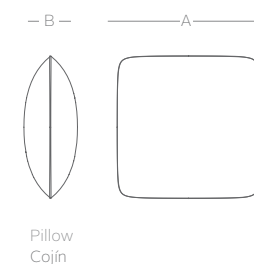

	A x B cm in	Ref.
Pillow 40 Cojín 40	40 x 40 x 15 15¾" x 15¾" x 6"	53020
Pillow 50 Cojín 50	50 x 50 x 15 19¾" x 19¾" x 6"	53025
Pillow 50 Cojín 50	50 x 35 x 15 19¾" x 13¾" x 6"	53023
Pillow 60 Cojín 60	60 x 60 x 15 23½" x 23½" x 6"	53024

MARQUIS COLLECTION by JMFerrero_Estudi{H}ac

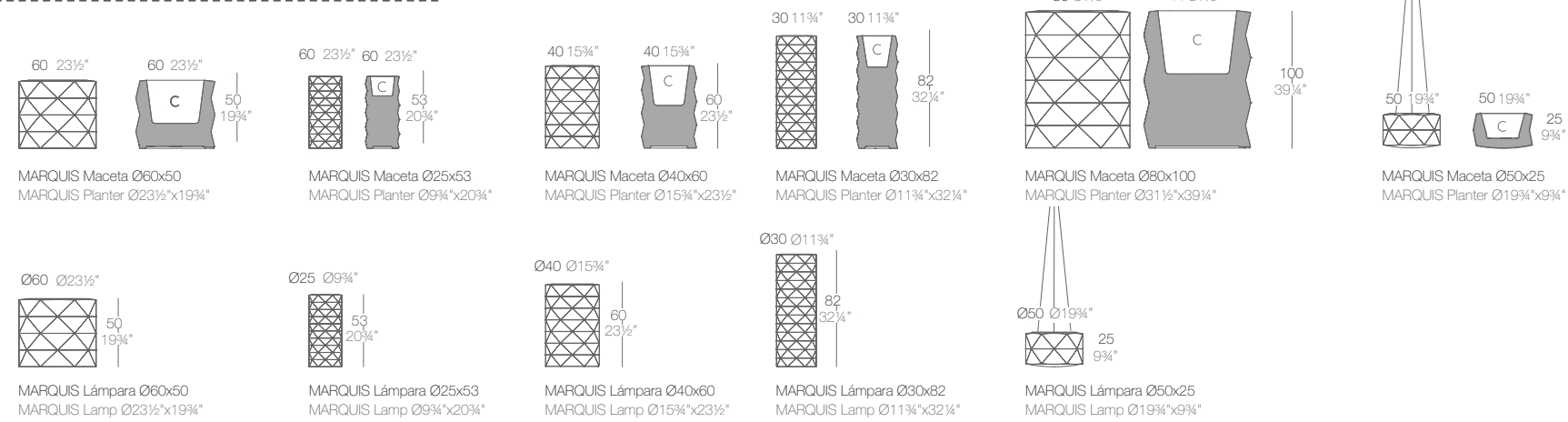

	L Gal	C (d x d') x h cm in	Basic	Self-Watering	Lacquered	Light	RGB Led	RGB Led DMX
Planter Ø23½"x19¾" Maceta Ø60x50		Ø43 x 32 Ø17" x 12½"	47081A	47081R	47081F	47081W	47081L	47081D
Planter Ø9¾"x20¾" Maceta Ø25x53		Ø18 x 14 Ø7" x 5½"	47082A	47082R	47082F	47082W	47082L	47082D
Planter Ø15¾"x23½" Maceta Ø40x60		Ø29 x 28 Ø11½" x 11"	47083A	47083R	47083F	47083W	47083L	47083D
Planter Ø11¾"x32¼" Maceta Ø30x82		Ø22 x 22 Ø8¾" x 8¾"	47084A	47084R	47084F	47084W	47084L	47084D
Planter Ø31½"x39¼" Maceta Ø80x100		Ø59 x 46 Ø23¼" x 18"	47085A	47085R	47085F	47085W	47085L	47085D
Hanging Planter Ø19¾"x9¾" Maceta Colgante Ø50x25		Ø38 x 22 Ø15" x 8¾"	47086A	47086R	47086F	-	-	-
Lamp Ø23½"x19¾" Lámpara Ø60x50	-	-	-	-	-	47087W	47087L	47087D
Lamp Ø9¾"x20¾" Lámpara Ø25x53	-	-	-	-	-	47088W	47088L	47088D
Lamp Ø15¾"x23½" Lámpara Ø40x60	-	-	-	-	-	47089W	47089L	47089D
Lamp Ø11¾"x32¼" Lámpara Ø30x82	-	-	-	-	-	47090W	47090L	47090D
Hanging Lamp Ø19¾"x9¾" Lámpara Colgante Ø50x25	-	-	-	-	-	47091W	47091L	47091D

AND COLLECTION by Fabio Novembre

	Basic	Lacquered	Light	RGB Led	RGB Led DMX	Cushion
Bench Banco	60007	60007F	60007W	60007L	60007D	60006CO
AND	60006	60006F	60006W	60006L	60006D	60007CO

2 x 60007 - AND
12 x 60006 - AND Bench

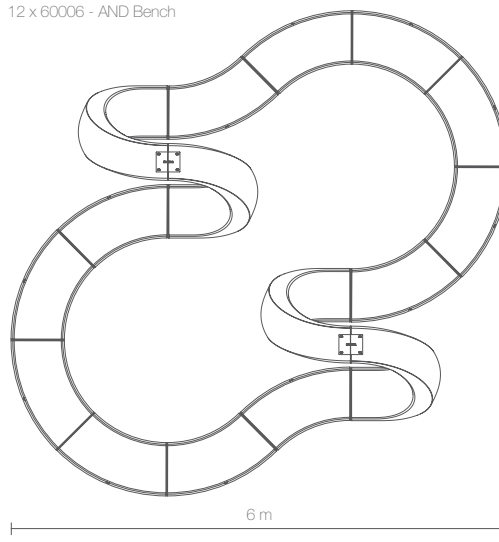

4 x 60007 - AND

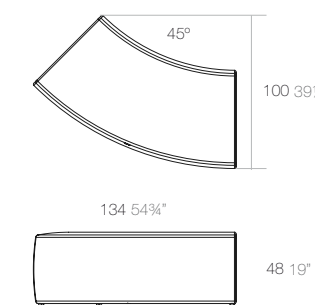
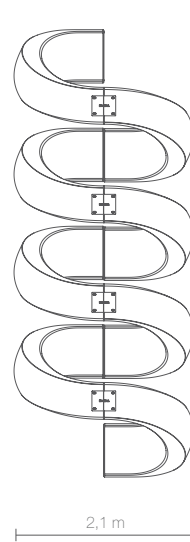

AND Banco
AND Bench

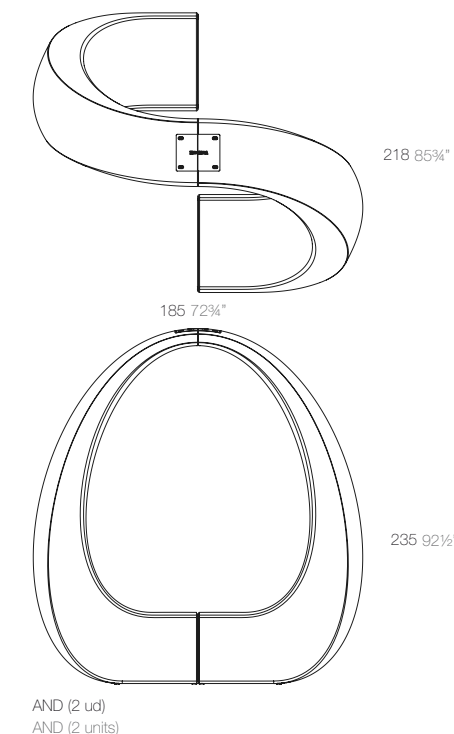

AND (2 ud)
AND (2 units)

FLAT COLLECTION by Jorge Pensi Design Studio

A

- 1 x 66001 - Sectional Right
- 1 x 66002 - Sectional Left
- 1 x 66003 - Sectional Central
- 1 x 66001 - Módulo Derecho
- 1 x 66002 - Módulo Izquierdo
- 1 x 66003 - Módulo Central

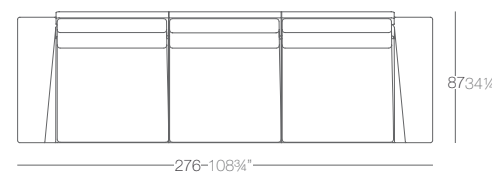

C

- 1 x 66001 - Sectional Right
- 1 x 66002 - Sectional Left
- 2 x 66003 - Sectional Central
- 1 x 66004 - Sectional Table
- 1 x 66001 - Módulo Derecho
- 1 x 66002 - Módulo Izquierdo
- 2 x 66003 - Módulo Central
- 1 x 66004 - Módulo Mesa

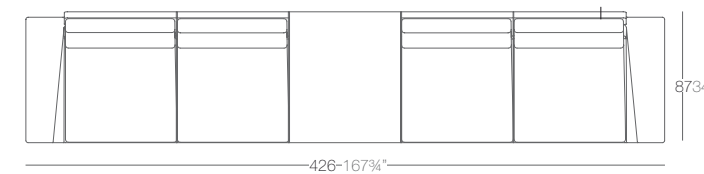

B

- 1 x 66001 - Sectional Right
- 1 x 66002 - Sectional Left
- 2 x 66003 - Sectional Central
- 1 x 66005 - Sectional Corner
- 1 x 66001 - Módulo Derecho
- 1 x 66002 - Módulo Izquierdo
- 2 x 66003 - Módulo Central
- 1 x 66005 - Módulo Corner

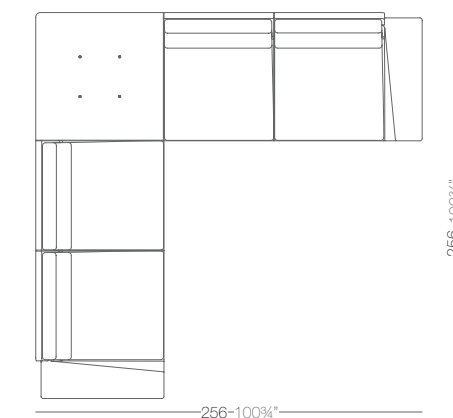

D

- 1 x 66001 - Sectional Right
- 1 x 66002 - Sectional Left
- 1 x 66003 - Sectional Central
- 1 x 66005 - Sectional Corner
- 1 x 66001 - Módulo Derecho
- 1 x 66002 - Módulo Izquierdo
- 1 x 66003 - Módulo Central
- 1 x 66005 - Módulo Corner

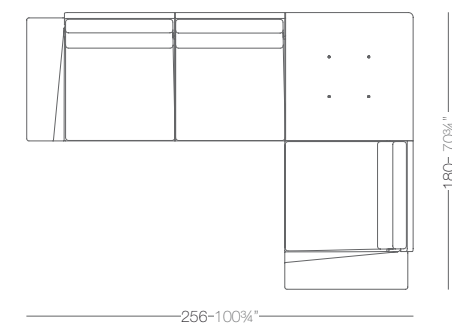

BUM BUM COLLECTION by Eugeni Quitlet

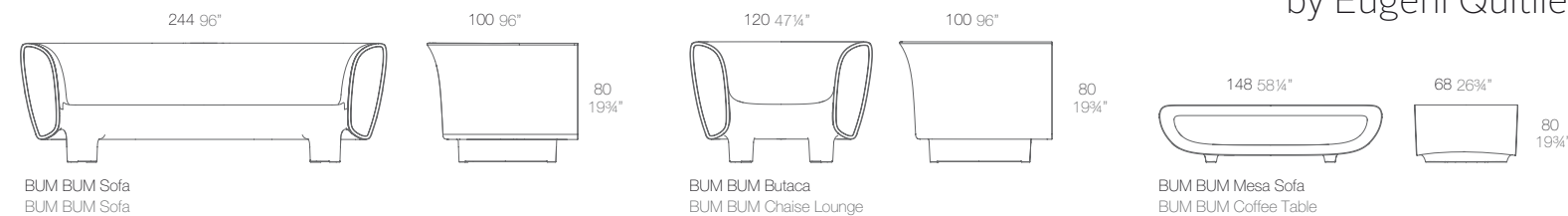

	Basic	Lacquered	Light	RGB Led	RGB Led DMX
Sofa Sofa	65001	65001F	65001W	65001L	65001D
Butaca Chaise Lounge	65008	65008F	65008W	65008L	65008D
Coffee Table Mesa Sofa	65007	65007F	65007W	65007L	65007D

VONDOM®

Head Quarters:

VONDOM S.L.U
Avda. Valencia - 46891 - El Palomar - Spain
t. +34 96 239 84 86 - f. +34 96 290 05 01
info@vondom.com - www.vondom.com

USA Branch:

VONDOM LLC.
979 Third Avenue - Suite 1532
PH: 917 494 0632 - New York, NY 10022
infousa@vondom.com - www.vondom.com

The possible differences between pictures and real items could be due to the colors in the printing technology process.

VONDOM all rights related to trademarks, pictures and designs are reserved.

All manufacturing distribution and/or trading activities in any media of the products displayed in the collections are prohibited. Specifically those rights about total or partial reproduction, transformation and/or usage in public with commercial purposes.

VONDOM reserves the right to effect any changes or improvements, without notice.

All the information included in this catalogue regarding sizes and capacities are approximated.

© Copyright. 2014. Vondom, S.L.U.

All rights reserved to the order of VONDOM

Las posibles diferencias entre el color original y el reproducido se deben a la técnica de impresión.

VONDOM se reserva el derecho exclusivo sobre todas las marcas, fotografías y diseños.

En particular quedan reservados los derechos de reproducción total o parcial, la transformación y/o su utilización de los mismo fuera de la esfera privada y con fines comerciales.

VONDOM se reserva el derecho de modificar total o parcialmente sin aviso previo cualquiera de los datos y especificaciones de esta publicación.

Toda la información que aparece en este catálogo referente a dimensiones y capacidades son aproximadas.

© Copyright. 2014. Vondom, S.L.U.

Todos los Derechos a beneficio de VONDOM

CD_0314

